

Serie P

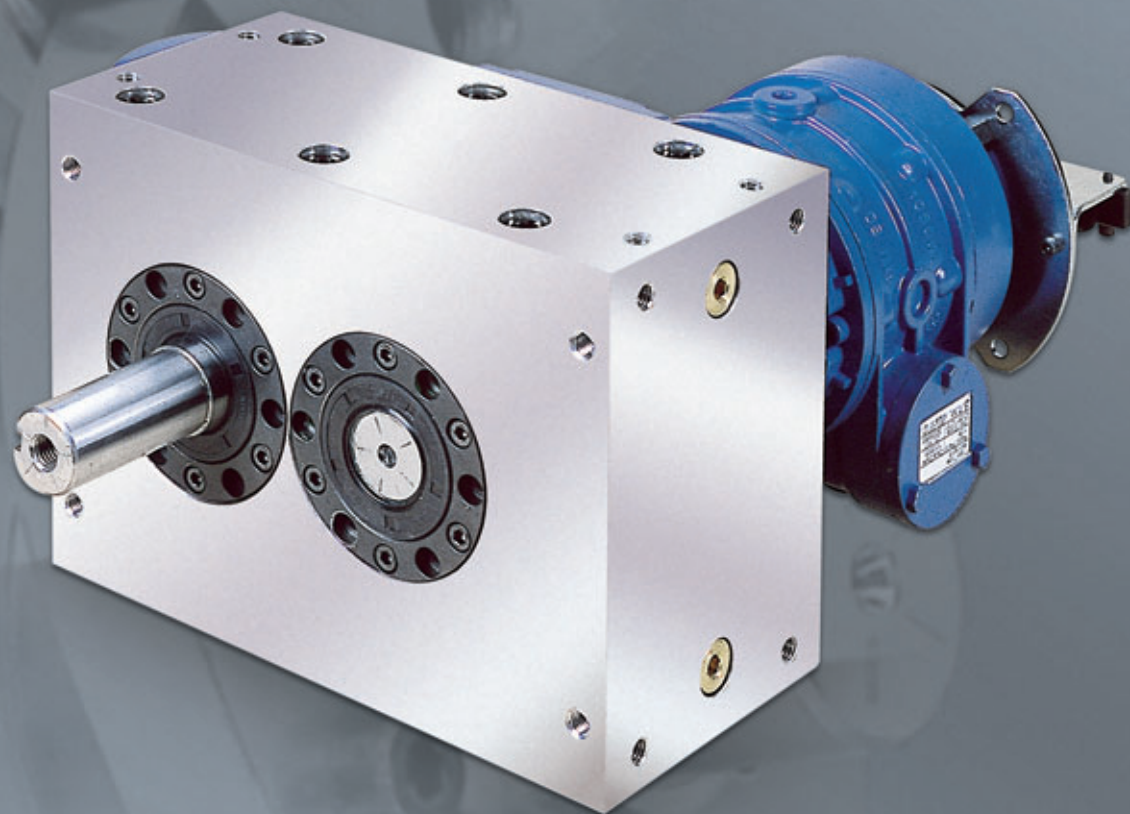

SOPAP



P 65 - 130



P 65 - 130

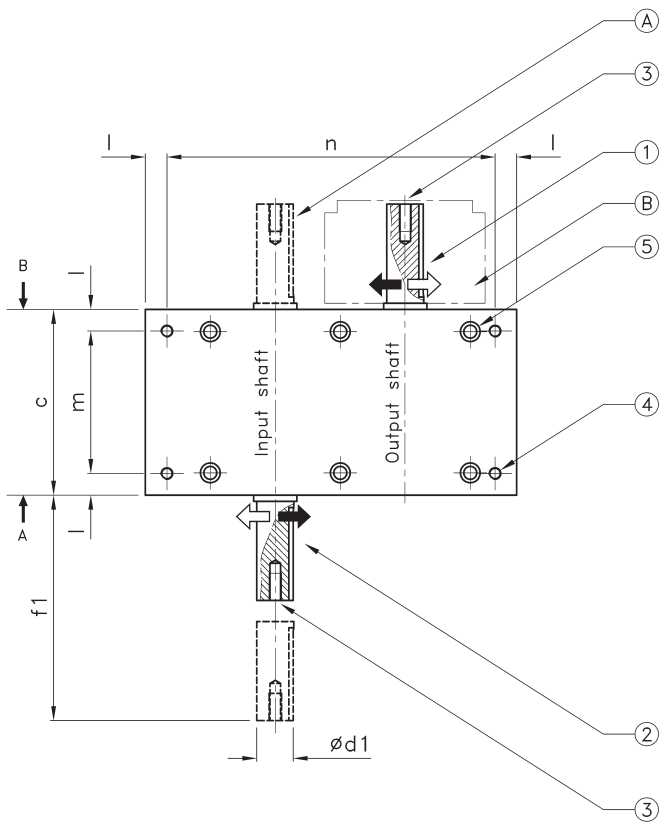
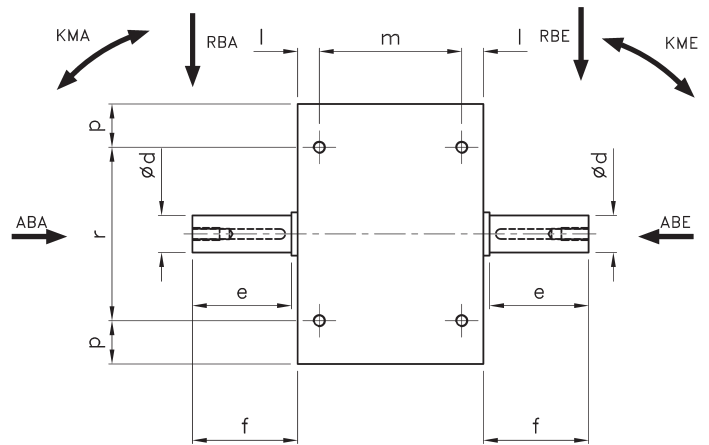
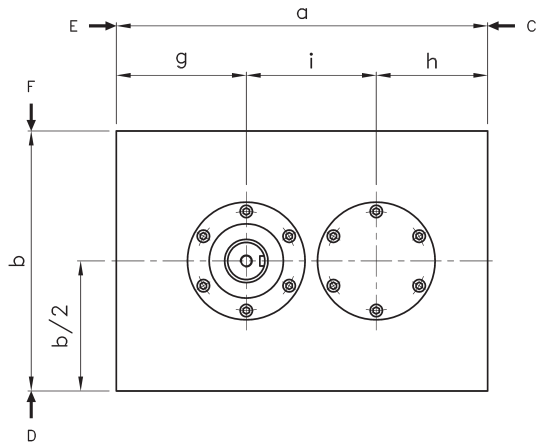

- ① Positioning of the key in the dwell phase (stop period)
- ② Positioning of the key in the dwell phase (middle of the stop period)
- ③ Threaded holes **U**
- ④ 4 fastening holes **S** on faces C, D, E and F
- ⑤ 6 assembly stud holes on faces D and F

Extra features on request

- Ⓐ Double input shaft
- Ⓑ Torque limiter at output

Dimensions without tolerances according to JS 13

Key normalised under DIN 6885

3 years warranty on standard products.

Dimensions

Size	P 65	P 80	P 105	P 130
a	190	240	300	370
b	140	180	210	260
c	95	120	150	180
Ø d k6	19	28	30	42
e	40	60	80	110
f	43	65	85	115
g	70	90	105	130
h	55	70	90	110
i	65	80	105	130
j	13	17	18	18
k	69	86	114	144
l	7,5	12,5	17,5	18
m	80	95	115	144
n	175	215	265	334
p	22,5	30	35	40
r	95	120	140	180
S	M6 x 12	M8 x 15	M10 x 20	M12 x 25
U	M6 x 16	M10 x 22	M10 x 22	M16 x 36
Ø d1 h6	20	30	35	45
f1	102	145	180	210
Weight (kg)	~ 8	~ 16	~ 27	~ 55

d1 and f1 are the biggest dimensions available on request.

Dimensions for reducers and motors; please contact us.

Remarks:

- This intermittent motion mechanism includes two coupled cams and a radial roller gear hub for the intermittent command of division plates, conveyors, etc.
- Vibrationless positive motion
- Lifetime grease
- Housing machined on all faces allowing all mounting positions
- Possible supply of single parts (cams and turret)
- Available with gear reducer or motor gear reducer
- Please avoid the mounting of elastic elements on the input and output shafts
- The inversion of the input shaft rotation will also provide an inversion of output shaft rotation without changing the kinematical characteristics

Technical characteristics

Size	65	80	105	130
Max. allowable axial load input shaft ABE (daN)	16	37	55	80
Max. allowable radial load input shaft RBE (daN)	65	140	200	250
Max. allowable tilting torque input shaft KME (daNm)	2,6	8,4	16	27,5
Max. allowable axial load output shaft ABA (daN)	32	75	110	160
Max. allowable radial load output shaft RBA (daN)	65	140	200	250
Max. allowable tilting torque output shaft KMA (daNm)	2,6	8,4	16	27,5
Additional fixed torque Mf1 (daNm)	1,2	1,5	2,5	3,5

Indexing unit Number of stops:

1 - 2 - 3 - 4 - 6 - 8

Further numbers of stop on request

Oscillating unit Angle of oscillation:

15° - 20° - 30° - 45°

Further angles of oscillation on request



SOPAP



SOPAP ensures quality and reliability

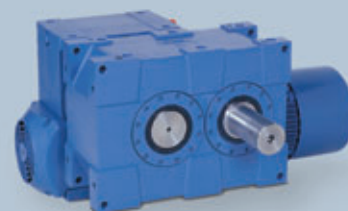

France

SOPAP SAS
Z.A.M Châlons Nord
1 Rue des Vignettes
F-51520 La Veuve

Téléphone: +33 (0) 3 26 69 21 21
Télécopie: +33 (0) 3 26 69 21 31
E.mail: info.fr@sopap.com

Deutschland Süd

SOPAP GmbH
Mittelöschstrasse 21
D-88213 Ravensburg

Telefon: +49 (0) 751 9507
Telefax: +49 (0) 751 92583
E.mail: info-sued.de@sopap.com

España

SOPAP Automatización S.L.
%Las Cruces nº6 – Bajo C
E-28230 Las Rozas
Madrid

Teléfono: +34 91 636 01 39
Teléfax: +34 91 636 02 64
E.mail: info.es@sopap.com

Benelux

ADR
Solvayweg 18
6049 CP Herten-Roermond
Nederland

Telefoon: +31 475 337379
Fax: +31 475 337444
E.mail: info.nl@sopap.com

Brasil

Triaxis
Rua Bulgária, 215
Vila Santa Luzia
09871-100 Sao Bernardo do Campo

Telefone: +55 11 4361 4977
Fax: +55 11 4361 9004
E.mail: info.br@sopap.com

Deutschland Mitte

Konstruktionsbüro Becker
Hch. Von Brentanoweg 2
D-64683 Einhausen

Telefon: +49 (0) 6251 856601
Telefax: +49 (0) 6251 987701
E.mail: info-mitte.de@sopap.com

USA

SOPAP LLC
560-A Brookshire Road
29651 Greer
South Carolina

Telephone: +1 864 801 1450
Fax: +1 864 801 1460
E.mail: info-sc.usa@sopap.com

USA

Rudy V. Colombi
2696 Red Fox Trail
48098 Troy
Michigan

Telephone: +1 248 840 2377
Fax: +1 248 540 7535
E.mail: info-mi.usa@sopap.com

Canada

DOLYX trading inc.
171 Nicholson Crt.
L7N 3N5 Burlington
Ontario

Telephone: +1 905 631 6615
Fax: +1 905 631 6244
E.mail: info-on.ca@sopap.com