

Serie MI

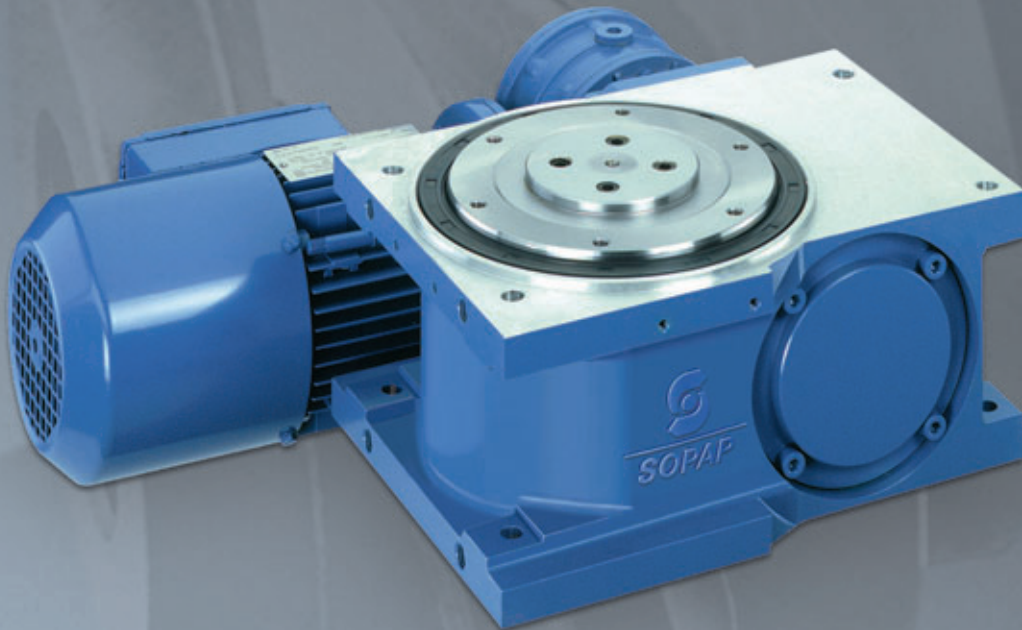

SOPAP

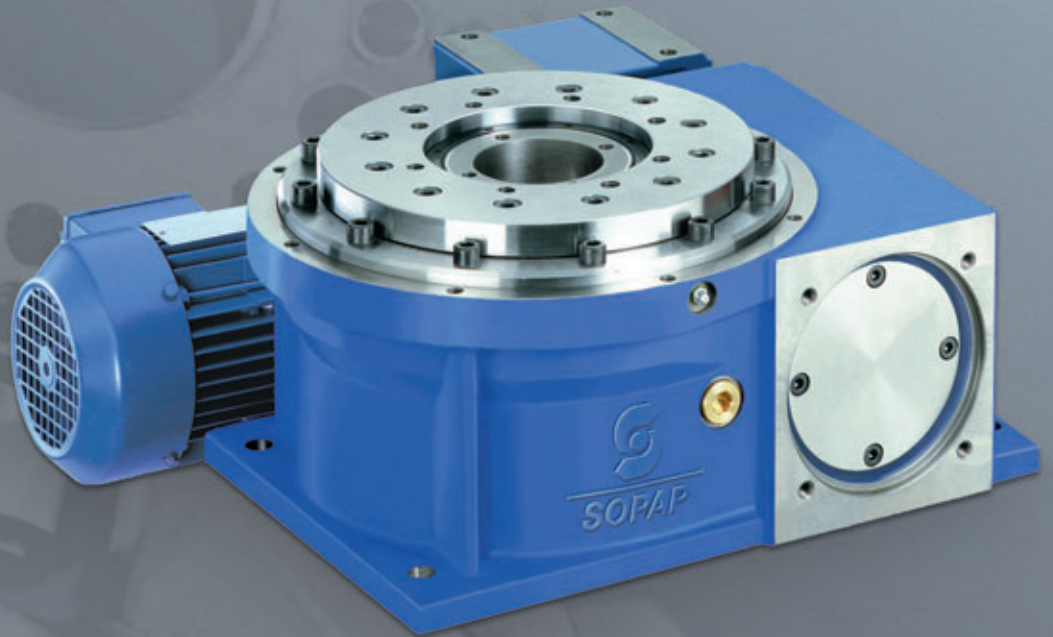

Mla 100 / 160

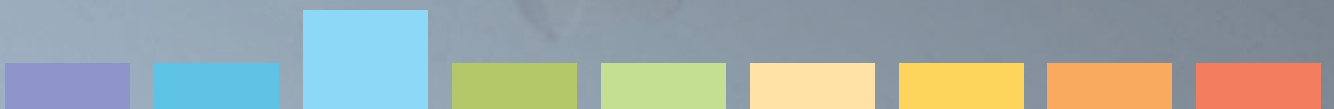

M1a 100

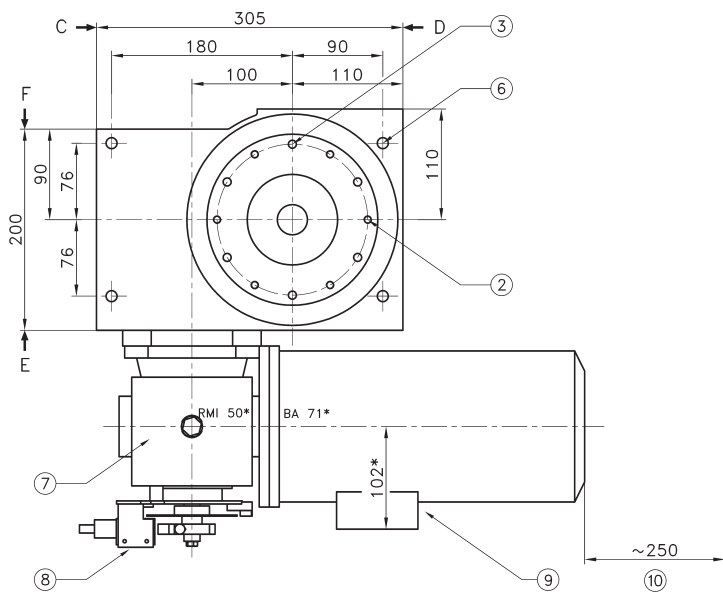
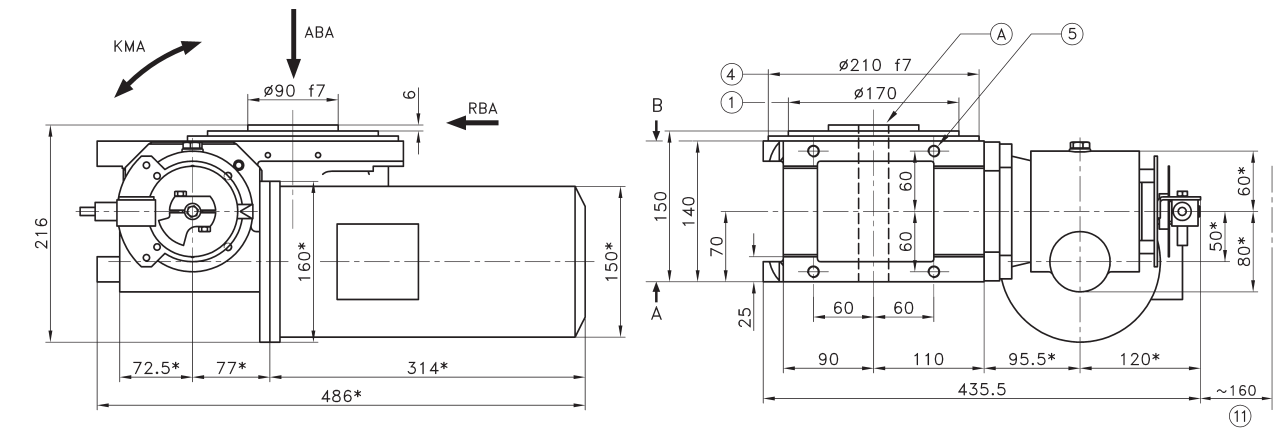

- ① Rotating
- ② 6 x M8 x 16 on $\varnothing 150$
Positioning of an indexing station
- ③ Possible pinning on $\varnothing 150$ max. depth 16
Undertaken by customer
- ④ Fix
- ⑤ 4 x M12 x 18
Faces C and D
- ⑥ 4 x $\varnothing 11$
Faces A and B
- ⑦ Reducer with torque limiter
- ⑧ Control cam and sensor
- ⑨ Brake-motor
- ⑩ Brake releasing area
- ⑪ Space for disassembly

* Dimensions depending on fitted motorisation.

Technical Characteristics

Repeatability	$\pm 0,01$ mm on $R_s = 60$ mm
Indexing accuracy	$\pm 0,02$ mm on $R_s = 60$ mm
Maxi allowable axial load ABA	10 000 N
Maxi allowable tilting torque KMA	1 000 Nm
Maxi allowable radial load RBA	15 000 N
Weight with motorisation	~ 50 kg

Extra features on request

- Ⓐ Hollow output shaft $\varnothing 30$

3 years warranty on standard products.

M1a 160

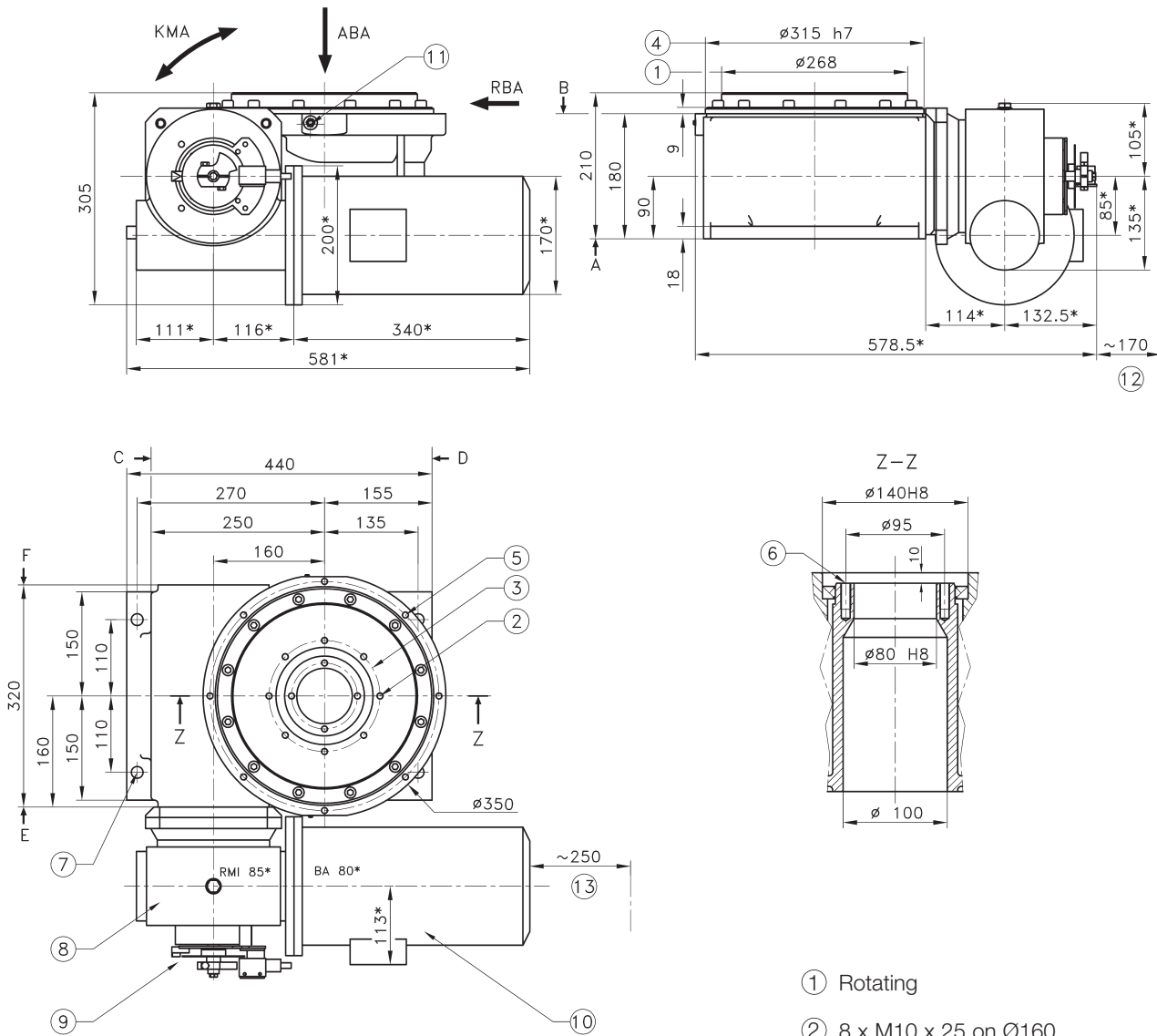

* Dimensions depending on fitted motorisation.

Technical Characteristics

Repeatability	$\pm 0,01$ mm on $R_s = 115$ mm
Indexing accuracy	$\pm 0,02$ mm on $R_s = 115$ mm
Maxi allowable axial load ABA	30 000 N
Maxi allowable tilting torque KMA	5 000 Nm
Maxi allowable radial load RBA	10 000 N
Weight with motorisation	~ 125 kg

- ① Rotating
- ② 8 x M10 x 25 on $\varnothing 160$
Positioning of an indexing station
- ③ Possible pinning on $\varnothing 160$ max. depth 25
Undertaken by customer
- ④ Fix
- ⑤ 8 x M10 x 16 on $\varnothing 330$
Fix
- ⑥ 4 x M10 x 25 on $\varnothing 95$
Fix
- ⑦ 4 x $\varnothing 17$
Faces A
- ⑧ Reducer with torque limiter
- ⑨ Control cam and sensor
- ⑩ Brake-motor
- ⑪ Lubricator faces E and F
- ⑫ Space for disassembly
- ⑬ Brake releasing area



SOPAP



SOPAP ensures quality and reliability



France

SOPAP SAS
Z.A.M Châlons Nord
1 Rue des Vignettes
F-51520 La Veuve

Téléphone: +33 (0) 3 26 69 21 21
Télécopie: +33 (0) 3 26 69 21 31
E.mail: info.fr@sopap.com

Deutschland Süd

SOPAP GmbH
Mittelöschstrasse 21
D-88213 Ravensburg

Telefon: +49 (0) 751 9507
Telefax: +49 (0) 751 92583
E.mail: info-sued.de@sopap.com

España

SOPAP Automatización S.L.
%Las Cruces nº6 – Bajo C
E-28230 Las Rozas
Madrid

Teléfono: +34 91 636 01 39
Teléfax: +34 91 636 02 64
E.mail: info.es@sopap.com

Benelux

ADR
Solvayweg 18
6049 CP Herten-Roermond
Nederland

Telefoon: +31 475 337379
Fax: +31 475 337444
E.mail: info.nl@sopap.com

Brasil

Triaxis
Rua Bulgária, 215
Vila Santa Luzia
09871-100 Sao Bernardo do Campo

Telefone: +55 11 4361 4977
Fax: +55 11 4361 9004
E.mail: info.br@sopap.com

Deutschland Mitte

Konstruktionsbüro Becker
Hch. Von Brentanoweg 2
D-64683 Einhausen

Telefon: +49 (0) 6251 856601
Telefax: +49 (0) 6251 987701
E.mail: info-mitte.de@sopap.com

USA

SOPAP LLC
560-A Brookshire Road
29651 Greer
South Carolina

Telephone: +1 864 801 1450
Fax: +1 864 801 1460
E.mail: info-sc.usa@sopap.com

USA

Rudy V. Colombi
2696 Red Fox Trail
48098 Troy
Michigan

Telephone: +1 248 840 2377
Fax: +1 248 540 7535
E.mail: info-mi.usa@sopap.com

Canada

DOLYX trading inc.
171 Nicholson Cr.
L7N 3N5 Burlington
Ontario

Telephone: +1 905 631 6615
Fax: +1 905 631 6244
E.mail: info-on.ca@sopap.com