

CenterClean™ patent pending

Food Grade Belting

Gates Mectrol CenterClean is designed for food processing applications requiring synchronous motion.

This self-tracking belt is ideal for 2" (51 mm) or larger pulley diameters. The HTD8 tooth profile helps to maintain pulley grooves free of debris and easily handles high acceleration and deceleration rates.

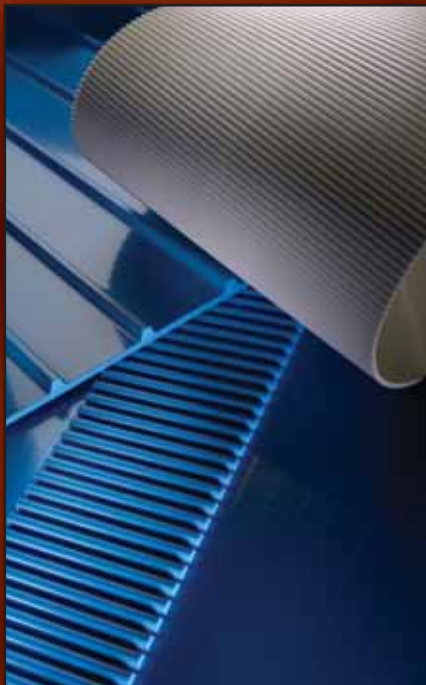
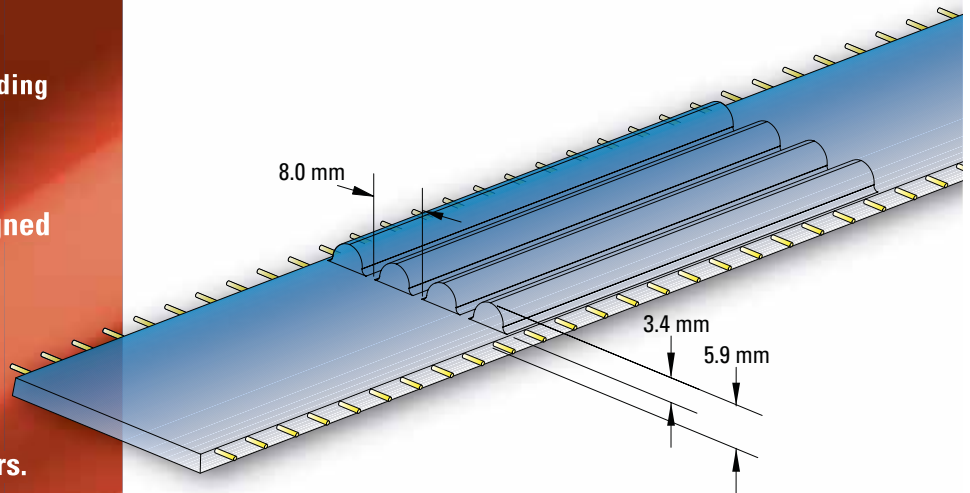

CenterClean belts are constructed with flexible urethane and sealed Kevlar® tension members. This construction allows CenterClean belts to be troughed and run on small diameter pulleys with minimal belt stretch.



IMAGINATION, DESIGN, EXECUTION

CenterClean

Features

- Smooth surface allows cleaning to a microbiological level and clean-in-place process
- Sealed edges and tension members preventing ingress of microbes
- Kevlar tension members provide high strength, low stretch
- No retensioning required
- Tough polyurethane construction
 - Water and chemical resistant
 - Meets FDA material requirements for wet food contact
- Self tracking

Benefits

- Food and confectionery conveying
- Wash down environments
- Synchronous motion
- High speed conveying
- Pulley diameters 2" (51 mm) or larger
- Troughing conveyor

CenterClean Specifications*

Pitch	mm	8
Max. Allowable Belt Tension per Inch or 25 mm Belt Width	lbf/in N/25 mm	60 270
Min. No. of Pulley Teeth		20
Min. Pitch Diameter	mm	51
Min. Diameter of Tensioning Idler Running on Back of Belt	inch mm	4.75 120
Hardness, Shore A		95
Service Temperature Range		-5° C to +70° C (23° F to 158° F)
Urethane Grade		FDA Compliant
Standard Color		Blue
Min. Welded Belt Length	mm	1000
Standard Roll Lengths	meters	60
Standard Slitting Lanes	inch	1
Min. Width Available	inch	8
Max. Width Available	inch	18
* Available Summer 2007		

The specifications listed are based on Gates Mectrol's experience. However, our specifications and data do NOT cover all possible belt drive conditions. It is the responsibility of the belt drive system designer to ensure Gates Mectrol's belts are appropriate for a given system and application.



Gates Mectrol, Inc.

9 Northwestern Drive
Salem, NH 03079
Tel. +1 (603) 890-1515 • Tel. +1 (800) 394-4844
Fax +1 (603) 890-1616
Email: contact@gatesmectrol.com
www.gatesmectrol.com

Gates Mectrol is a registered trademark and CenterClean is a trademark of Gates Mectrol Incorporated. All other trademarks used herein are the property of their respective owners.

© Copyright 2007 Gates Mectrol Incorporated. All rights reserved.

GM CenterClean 1-2007