

STROKE BUSH

SLIDE ROTARY BUSH

SLIDE GUIDE

BALL SPLINE
ROTARY BALL SPLINE
STROKE BALL SPLINE

TOPBALL® PRODUCTS

SLIDE BUSH

SLIDE UNIT

STROKE BUSH
SLIDE ROTARY BUSH

SLIDE SHAFT

SLIDE WAY/GONIO WAY
SLIDE TABLE
MINIATURE SLIDE

ACTUATOR

SLIDE SCREW

STROKE BUSH

The NB stroke bush is a linear and rotational motion mechanism utilizing the rotational motion of ball elements between an outer cylinder and a shaft. It is compact and can stand high loading. The retainer is made of a light metal alloy with high wear resistance. Smooth motion is achieved under high-speed and high-acceleration conditions. Although the linear motion is limited to a predetermined stroke distance, the smooth combination of linear and rotational motions is achieved with very little frictional resistance. The NB stroke bush may be conveniently used in a variety of applications.

STRUCTURE AND ADVANTAGES

The retainer in the NB stroke bush positions the ball elements in a zigzag arrangement. The inner surface of the outer cylinder is finished by grinding, resulting in the smooth motion of the ball elements. Each of the ball elements is held in a separate hole and smooth motion is achieved for both rotational motion and linear motion. The retainer moves half the distance of the linear motion, therefore, the stroke distance is limited to approximately twice the distance the retainer can travel within the outer cylinder. The actual stroke should be limited to 80% of the maximum stroke as listed in the dimensional tables.

● High Precision

High-carbon, chromium-bearing steel is used for the outer cylinder. It is heat treated and ground to achieve high rigidity and accuracy.

● Ease of Mounting / Replacement

The highly accurate fabrication of the NB stroke bush results in uniform dimensions, facilitating parts replacement and housing fabrication.

● Light Weight / Space Saving

The use of an aluminum alloy for the retainer and the thin-wall outer cylinder make the NB stroke bush light weight and compact.

● Lubrication

Lubrication holes are provided on the oil grooves of the outer cylinder, making it easy to lubricate the SR stroke bush.

Figure F-1 Structure of SR Stroke Bush

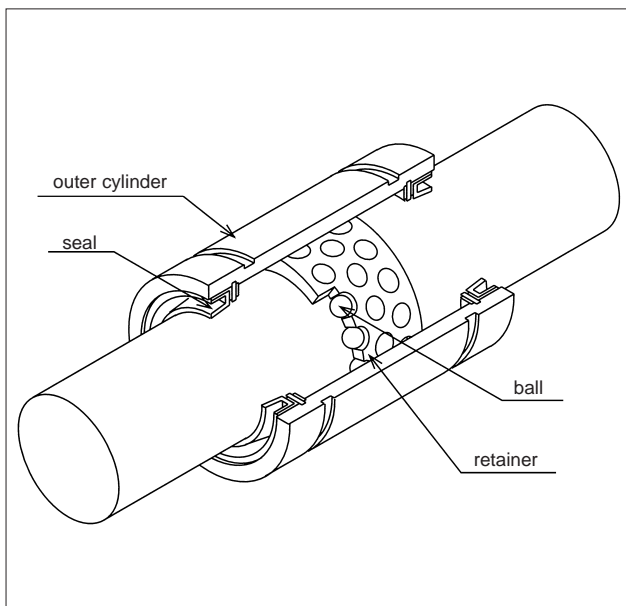

ACCURACY

The accuracies of the SR stroke bush are stated in the dimensional tables. Since the outer cylinder deforms due to tension from the retaining ring, the dimension of the outer cylinder is an average value at points P, where calculated using the following equation:

$$W = 4 + \frac{L}{8}$$

W : the distance from the end of the outer race to measurement point P
 L : the length of the outer race

FIT

The inner contact diameters of the SR stroke bush are listed in the dimensional tables. The shaft diameter tolerance should be selected to achieve the desired amount of radial clearance. High-speed linear motion can cause the retainer to slip due to inertial force. An interference fit of -3 to $-10 \mu\text{m}$

Figure F-2 Outer Cylinder Measurement Points

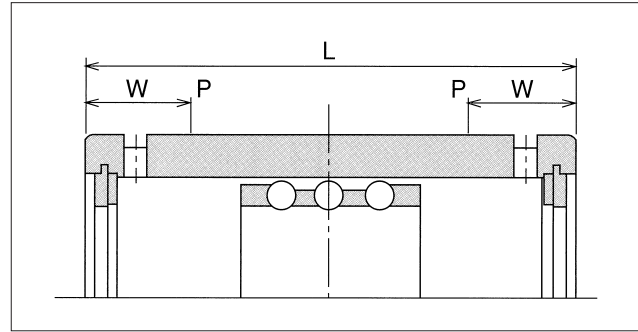

will compensate for such slip. The fits generally used between the shaft and the housing are listed in the table below.

Table F-1

normal operating condition		vertical use or highly accurate case	
shaft	housing	shaft	housing
k5,m5	H6,H7	n5,p6	J6,J7

RATED LOAD AND RATED LIFE

The relationship between the rated load and life of the stroke bush is expressed as follows:

$$L = \left(\frac{C}{P}\right)^3$$

L : the rated life (10^6 rotations), C : the basic dynamic rated load (N)
 P : load (N)

● For rotation/stroke combined motion

$$L_h = \frac{10^6 \cdot L}{60 \sqrt{(dm \cdot n)^2 + (10 \cdot S \cdot n_1)^2} / dm}$$

● For stroke motion

$$L_h = \frac{10^6 \cdot L}{600 \cdot S \cdot n_1 / (\pi \cdot dm)}$$

L_h : travel life in time (hr) S : stroke distance (mm)
 n : revolution per min. (rpm)
 n_1 : stroke frequency per min. (cpm)
 dm : ball pitch diameter (mm) ≈ 1.15 dm

ALLOWABLE SPEED FOR COMBINED ROTATION/STROKE MOTION

The allowable speed for combined rotation and stroke motion is obtained from the following equation:

$$DN \geq dm \cdot n + 10 \cdot S \cdot n_1$$

The value of DN is given as follows depending on the lubrication method.

for oil lubrication	DN=600,000
for grease lubrication	DN=300,000

note..... $n \leq 5,000$ $S \cdot n_1 \leq 50,000$

SR-UU TYPE

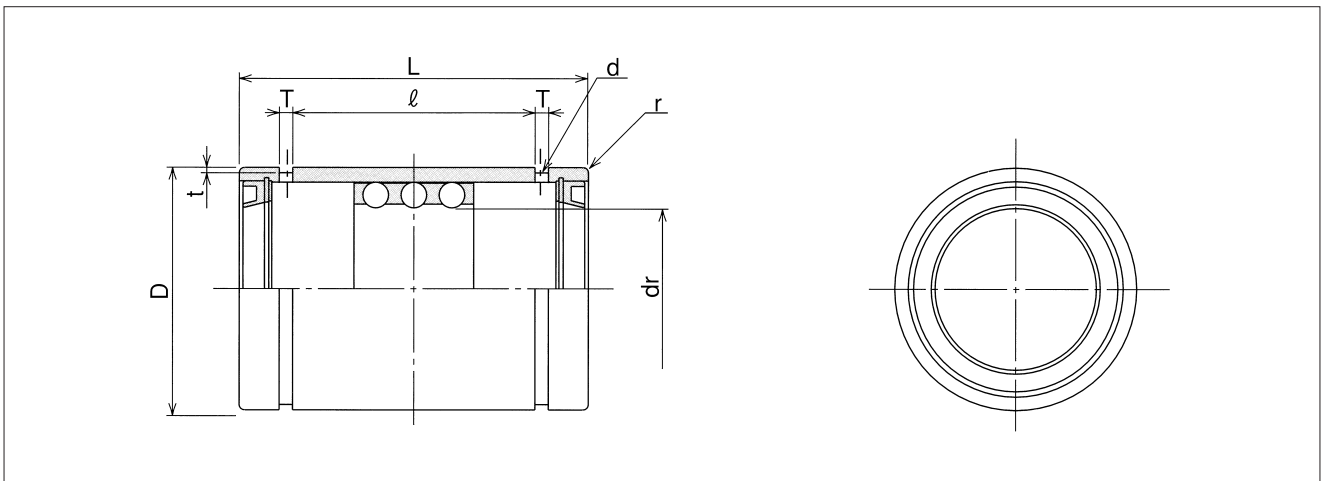
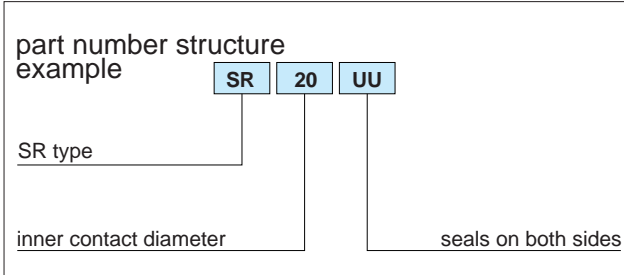

part number	maximum stroke mm	number of rows	major dimensions											basic load rating		mass g
			dr		D		L		ℓ	T	t	d	r	dynamic C N	static Co N	
			mm	tolerance μm	mm	tolerance μm	mm	tolerance mm								
SR 8UU	14	3	8	+22	15	0/-11	24	0	12.3	1.5	0.5	1.2	0.5	343	245	15.6
SR 10UU	16	3	10	+13	19	0	30		15.5	1.5	0.5	1.2	0.5	637	461	28.8
SR 12UU	17	3	12	+27	23	-13	32		17.1	1.5	0.5	1.2	0.5	1,070	813	42
SR 16UU	24	3	16	+16	28		37	-0.2	21.1	1.5	0.7	1.3	0.5	1,180	990	71
SR 20UU	32	3	20	+33	32	0	45		26.8	2	0.7	1.5	0.5	1,260	1,170	99
SR 25UU	32	3	25	+20	37	-16	45	0	26.8	2	0.7	1.6	1	1,330	1,330	117
SR 30UU	65	3	30		45		65		45.1	2.5	1	2	1	2,990	3,140	205
SR 35UU	75	3	35	+41	52	0	70		50.1	2.5	1	2	1.5	3,140	3,530	329
SR 40UU	91	3	40	+25	60	-19	80	-0.3	59.9	2.5	1	2	1.5	4,120	4,800	516
SR 50UU	120	3	50		72		100		77.4	3	1	2.5	1.5	5,540	6,910	827
SR 60UU	120	3	60	+49	85	0	100	0	77.4	3	1	2.5	2	5,980	8,230	1,240
SR 80UU	114	3	80	+30	110	-22	100		77	3	1.5	2.5	2	7,840	12,200	2,050
SR100UU	114	3	100	+58/+36	130	0/-25	100	-0.4	77	3	1.5	2.5	2	8,430	14,700	2,440

1N \approx 0.102kgf

SR-B TYPE

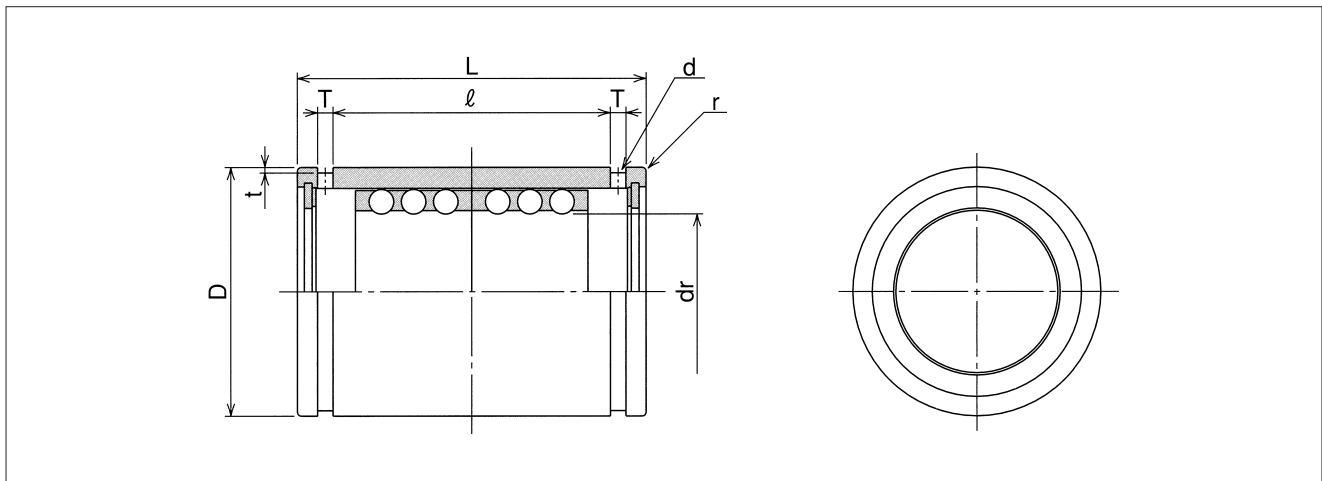
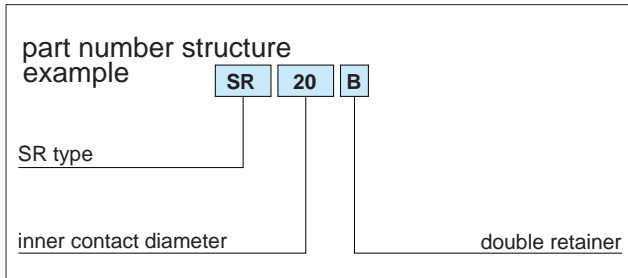

part number	maximum stroke mm	number of rows	major dimensions											basic load rating		mass g
			dr		D		L		ℓ	T	t	d	r	dynamic C N	static Co N	
			mm	tolerance μm	mm	tolerance μm	mm	tolerance mm								
SR 8B	8	6	8	+22	15	0/-11	24	0	17.1	1.5	0.5	1.2	0.5	549	490	16.8
SR 10B	8	6	10	+13	19	0	30		22.7	1.5	0.5	1.2	0.5	1,030	931	31.2
SR 12B	8	6	12	+27	23	-13	32		24.5	1.5	0.5	1.2	0.5	1,720	1,630	46
SR 16B	16	6	16	+16	28	-13	37	-0.2	29.1	1.5	0.7	1.3	0.5	1,910	1,980	75
SR 20B	20	6	20	+33	32	0	45		35.8	2	0.7	1.5	0.5	2,060	2,320	106
SR 25B	20	6	25	+20	37	0	45		35.8	2	0.7	1.6	1	2,170	2,670	125
SR 30B	44	6	30	+20	45	-16	65	-0.3	53.5	2.5	1	2	1	4,800	6,270	220
SR 35B	54	6	35	+41	52	0	70		58.5	2.5	1	2	1.5	5,050	7,060	346
SR 40B	66	6	40	+25	60	-19	80		68.3	2.5	1	2	1.5	6,710	9,560	540
SR 50B	88	6	50	+49	72	-19	100	0	86.4	3	1	2.5	1.5	8,970	13,800	862
SR 60B	88	6	60	+30	85	0	100		86.4	3	1	2.5	2	9,700	16,500	1,290
SR 80B	76	6	80	+58/+36	110	-22	100		86	3	1.5	2.5	2	12,700	24,300	2,110
SR100B	76	6	100	+58/+36	130	0/-25	100	-0.4	86	3	1.5	2.5	2	13,700	29,400	2,520

1N \approx 0.102kgf

SR-BUU TYPE

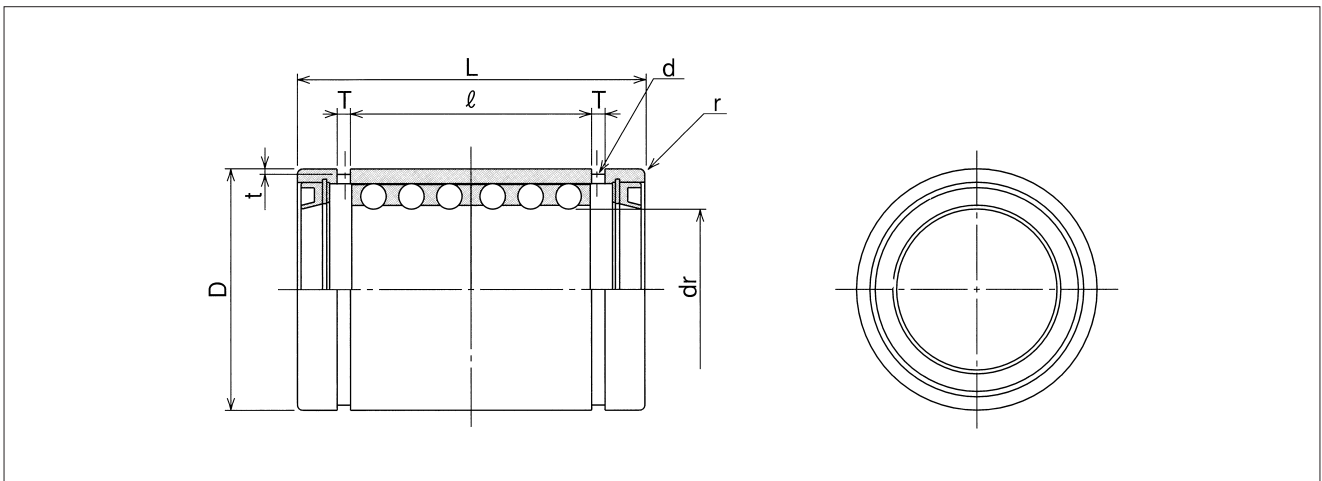
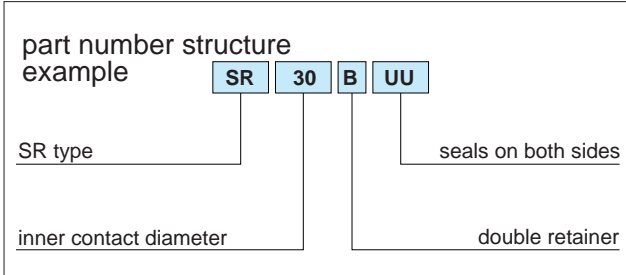

part number	maximum stroke mm	number of rows	major dimensions											basic load rating		mass g
			dr		D		L		ℓ	T	t	d	r	dynamic C N	static Co N	
			mm	tolerance μm	mm	tolerance μm	mm	tolerance mm								
SR 30BUU	27	6	30	+33/+20	45	0/-16	65	0	45.1	2.5	1	2	1	4,800	6,270	220
SR 35BUU	37	6	35	+41	52	0	70		50.1	2.5	1	2	1.5	5,050	7,060	346
SR 40BUU	49	6	40	+25	60	-19	80	-0.3	59.9	2.5	1	2	1.5	6,710	9,560	540
SR 50BUU	70	6	50	+25	72	-19	100		77.4	3	1	2.5	1.5	8,970	13,800	862
SR 60BUU	70	6	60	+49	85	0	100	0	77.4	3	1	2.5	2	9,700	16,500	1,290
SR 80BUU	58	6	80	+30	110	-22	100		77	3	1.5	2.5	2	12,700	24,300	2,110
SR100BUU	58	6	100	+58/+36	130	0/-25	100	-0.4	77	3	1.5	2.5	2	13,700	29,400	2,520

1N \approx 0.102kgf

SLIDE ROTARY SERIES

NB's Slide Rotary Series consists of three different types. The Slide Rotary Bush, which provides both endless rotary and linear motion functions, the Flanged Slide Rotary Bush, and the Slide Rotary Unit which is assembled using various NB standard housings.

The NB Slide Rotary Series has an idealistic structure, incorporating a combination of linear and rotary motion. Linear and rotary motion are merged into a single unit resulting in great space savings compared to the conventional style of Slide Bushings. All three types of the Slide Rotary Series are available in sizes ranging from 6mm to 30mm. All components in the Slide Rotary Series are standardized for versatile installation requirements.

STRUCTURE AND ADVANTAGES

NB Slide Rotary Bush is composed of retainer fitted into cylindrical steel outer race and is designed to guide steel balls for smooth circulation in its retainer. The retainer is also designed to rotate freely towards radial direction and offers smooth linear and rotary motions.

Smooth Operation

The inner surface of the outer race allows smooth operation of linear and rotary motions while maintaining a uniform load distribution.

High Load Capacity

The use of comparatively large diameter steel balls enhances acceptability of high load capacity.

Smooth Rotation

The positioning of the steel balls in a cylindrical formation inside the retainer enables a smooth rotational motion to be achieved independent of the installation direction.

Complete Interchangeability

NB Slide Rotary series is completely interchangeable with SM type Slide Bush, SMK type Flanged Slide Bush and Slide Units such as SMA(W) type, AK(W) type and SMP type.

Figure F-3 Structure of SRE-type NB slide rotary bush

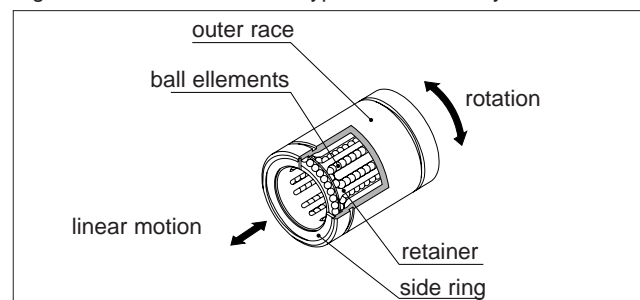

RATED LIFE AND LOADS

The rated life and loads are defined as follows.

Rated Life

When a group of slide rotary bearings of the same type are used under the same conditions, the rated life is defined as the total number of rotations made without flaking by 90% of the bearings.

Basic Dynamic Rated Load

The basic dynamic rated load is defined as the load with a constant magnitude and direction at which a rated life of 10^6 rotations can be achieved.

Basic Static Rated Load

The basic static rated load is defined as the load with a constant direction that would result in a certain contact stress at the mid-point of the rolling element and tracking surface that are experiencing the maximum stress.

Formula 1 gives the relation between the applied load and the rated life of the slide rotary bush.

Calculation Example

The life of an SRE20-type NB slide rotary bush is calculated below based on the following operating conditions.

Conditions

- Motions : Linear and rotational, combined
- Load, P : 30 N
- Stroke, S : 200 mm
- Number of rotations per minute (rpm), n=15

Calculation:

Basic rated load, C=647 N

Based on the above operating conditions, the life is calculated using the following coefficient values.

Hardness coefficient, $f_H=1$ Temperature coefficient, $f_T=1$ Contact coefficient, $f_C=1$ Load coefficient, $f_W=1.5$
Rated life

$$L = \left(\frac{f_H \cdot f_T \cdot f_C}{f_W} \cdot \frac{C}{P} \right)^3$$

$$= \left(\frac{1 \times 1 \times 1}{1.5} \times \frac{647}{30} \right)^3 = 2,972 \text{ (} 10^6 \text{ rotations)}$$

$$L = \left(\frac{f_H \cdot f_T \cdot f_C}{f_W} \cdot \frac{C}{P} \right)^3 \dots\dots\dots ①$$

L : rated life (10^6 rotations) f_H : hardness coefficient
 f_T : temperature coefficient f_C : contact coefficient
 f_W : load coefficient C : basic dynamic rated load (N)
 P : applied load (N)

Since the slide rotary bush is used in applications with combined linear and rotary motions, the life time is obtained using Formulas ② and ③.

When linear and rotary motions are combined

$$L_h = \frac{10^6 \cdot L}{60 \sqrt{(dm \cdot n)^2 + (10 \cdot S \cdot n_1)^2} / dm} \dots\dots\dots ②$$

When only linear motion is involved

$$L_h = \frac{10^6 \cdot L}{600 \cdot S \cdot n_1 / \pi \cdot dm} \dots\dots\dots ③$$

L_h : life (hours) S : stroke (mm) n : number of rotations per minute (rpm) n_1 : number of strokes per minute (cpm)
 dm : ball pitch diameter (mm) = approx. 1.15 dr (dr is the inner contact diameter of the SRE-type bush)

- Number of strokes per minute (cpm), $n_1=10$
- Shaft surface hardness : greater than 58 HRC
- Operating temperature : room temperature
- Other : single shaft with single bush

Life (in time)

$$L_h = \frac{10^6 \cdot L}{60 \sqrt{(dm \cdot n)^2 + (10 \cdot S \cdot n_1)^2} / dm}$$

$$L_h = \frac{10^6 \cdot L}{60 \sqrt{(1.15 \times 20 \times 15)^2 + (10 \times 200 \times 10)^2} / (1.15 \times 20)}$$

$$= 56,900 \text{ (hours)}$$

Application Examples

Application Example 1 Vertical Shaft Robot Arm

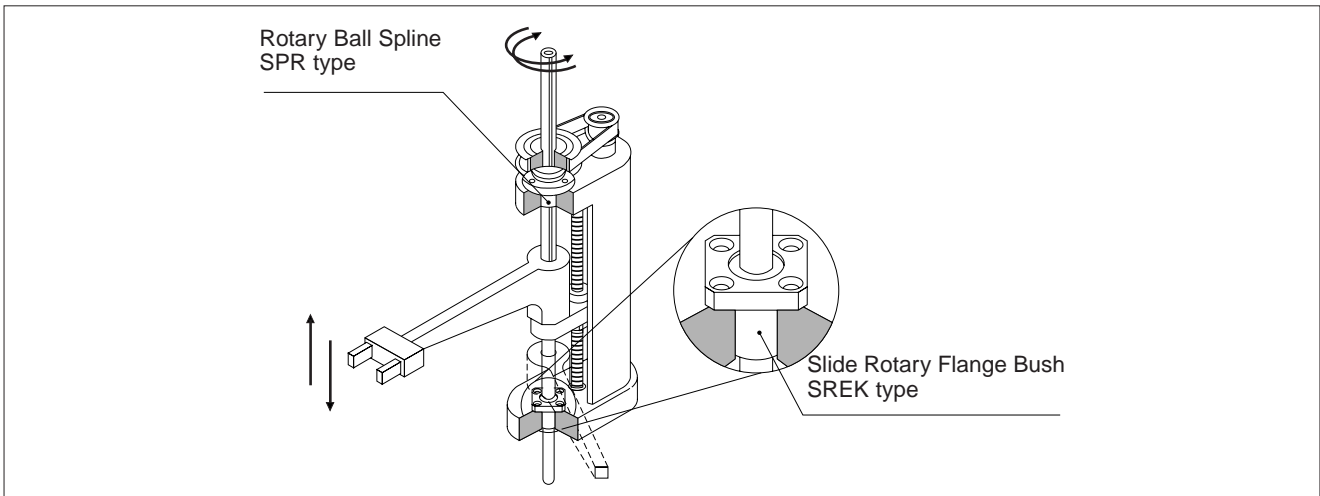

Application Example 2 Multiple Gearing Idler

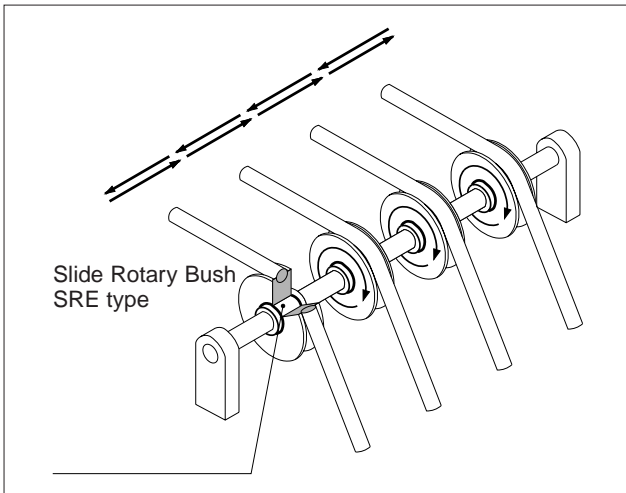

Application Example 4 Turntable

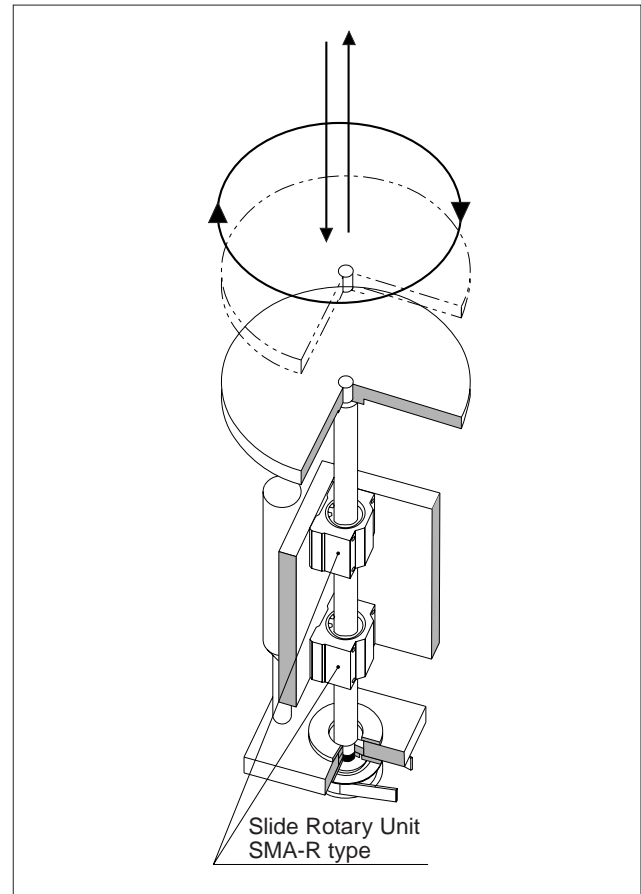

Application Example 3 Tool Changer

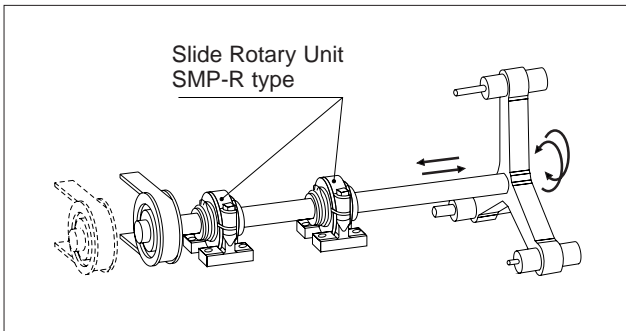

Precautions Regarding Use

Shaft

Since the balls roll directly over the shaft surface in the SRE-type slide rotary bush, the accuracy and hardness of the shaft are important factors.

Outer Diameter : A tolerance of g6 is recommended for smooth operation.

Hardness : A hardness of greater than 58HRC is recommended for long life. If the hardness is less than 58 HRC, the life is calibrated using the hardness coefficient.

Surface Roughness : A roughness of less than 0.4Ra is recommended.

Housing

An inner diameter tolerance of H7 is recommended.

Lubrication

Lubrication is needed (1) to prevent heat fusing and reduce wear between the rolling elements and between the rolling elements and the tracking surface, (2) to reduce wear of the structural elements, and (3) to prevent oxidation. Lubrication affects both the performance and life of the bush. A lubrication

method and a lubrication agent appropriate to the operating conditions should be used. For oil lubrication, turbine oil (V32-68) should be used. For grease lubrication, lithium soap grease no. 2 should be used. The replenishment interval depends on the operating conditions.

Dust Control

Dust and other contaminants affect the bush's lifetime and accuracy. Appropriate control methods are thus important.

Operating Temperature Range

The SRE-type bush can be operated at temperatures ranging from -20°C to 110°C . In a case of operating at a temperature outside this range, please contact NB.

Retainer Material

The standard material of SRE Retainer is "Phosphor Bronze". When requiring other material, please contact NB.

Felt Seal

The use of an FLM felt seal will improve the effectiveness of lubrication and extend the interval between applications of a lubricant.

Figure F-4 Felt seal diagram

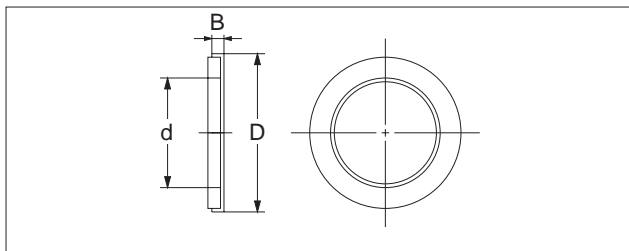

Installation

The felt seal should be installed as shown in Figure F-5. Please note that felt seal is not designed for stopper function.

Table F-2 Felt seal dimensions

part number	major dimensions			applicable slide rotary bush
	d	D	B	
FLM 6	6	12	2	SRE 6
FLM 8	8	15	2	SRE 8
FLM10	10	19	3	SRE10
FLM12	12	21	3	SRE12
FLM13	13	23	3	SRE13
FLM16	16	28	4	SRE16
FLM20	20	32	4	SRE20
FLM25	25	40	5	SRE25
FLM30	30	45	5	SRE30

Figure F-5 Example of Installation

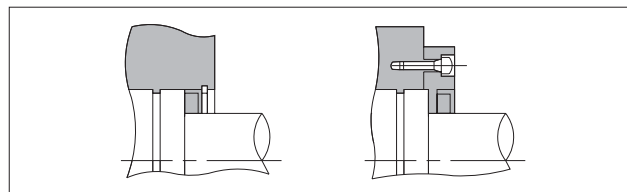

SRE TYPE

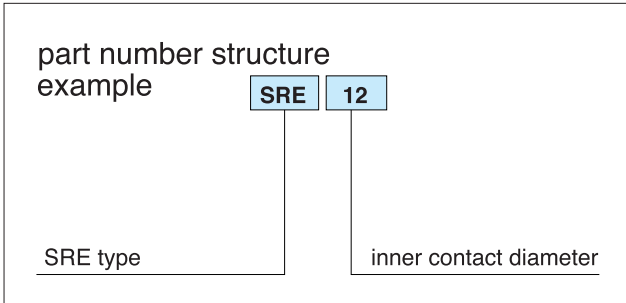

part number	major dimensions							
	inner contact diameter		D		L		B	
	dr	tolerance		tolerance		tolerance		tolerance
	mm	μm	mm	mm	mm	mm	mm	mm
SRE 6	6	+4 -5	12	0	19	0 -0.2	13.5	0 -0.2
SRE 8	8		15	-11	24		17.5	
SRE10	10		19		29		22	
SRE12	12	+3 -6	21	0	30	-0.2	23	-0.2
SRE13	13		23	-13	32		23	
SRE16	16		28		37		26.5	
SRE20	20	+3 -7	32	0	42	0 -0.3	30.5	0 -0.3
SRE25	25		40	-16	59		41	
SRE30	30		45		64		44.5	

*If the inner contact diameter exceeds 30 mm, please contact NB.

SLIDE ROTARY BUSH

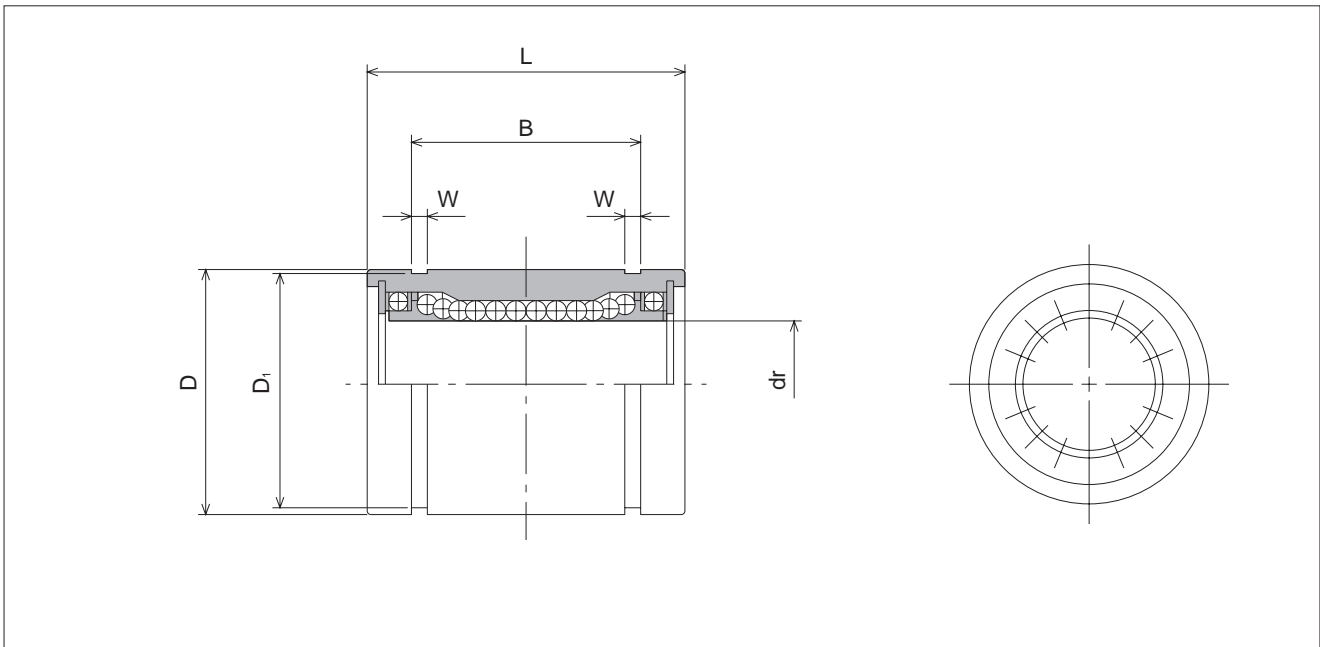

W	D ₁	basic load rating		allowable number of rotations per minute	number of ball circuit	mass	part number
		dynamic C	static C ₀				
mm	mm	N	N	rpm		g	
1.1	11.5	78	176	300	6	9	SRE 6
1.1	14.3	137	314	300	8	15	SRE 8
1.3	18	157	372	300	8	20	SRE10
1.3	20	274	588	300	8	40	SRE12
1.3	22	323	686	300	8	45	SRE13
1.6	27	451	882	250	8	65	SRE16
1.6	30.5	647	1,180	250	8	110	SRE20
1.85	38	882	1,860	250	8	210	SRE25
1.85	43	1,180	2,650	200	8	290	SRE30

1N ≙ 0.102kgf

SREK TYPE

— Square Flange type —

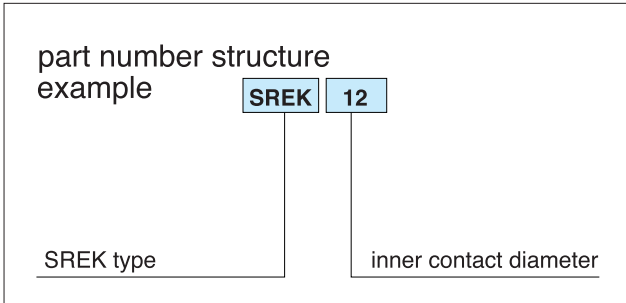
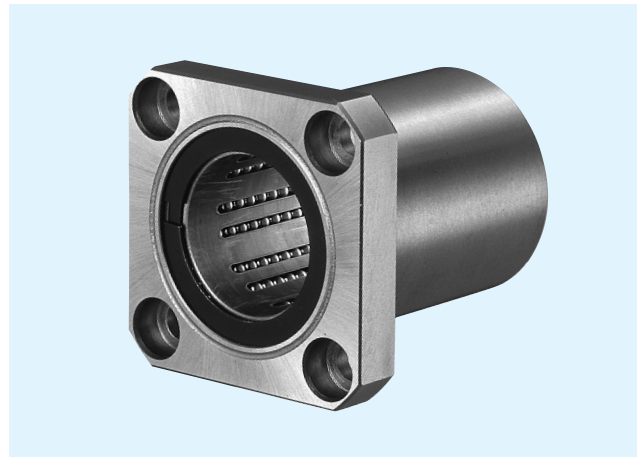

part number	major dimensions						
	inner contact diameter		D		L ±0.3	Df	K
	dr mm	tolerance μm	mm	tolerance μm			
SREK 6	6	+4 -5	12	0	19	28	22
SREK 8	8		15	-13	24	32	25
SREK10	10		19	0 -16	29	40	30
SREK12	12	21	30		42	32	
SREK13	13	23	32		43	34	
SREK16	16	-6	28	0 -19	37	48	37
SREK20	20	+3 -7	32		42	54	42
SREK25	25		40		59	62	50
SREK30	30		45	64	74	58	

SLIDE ROTARY BUSH

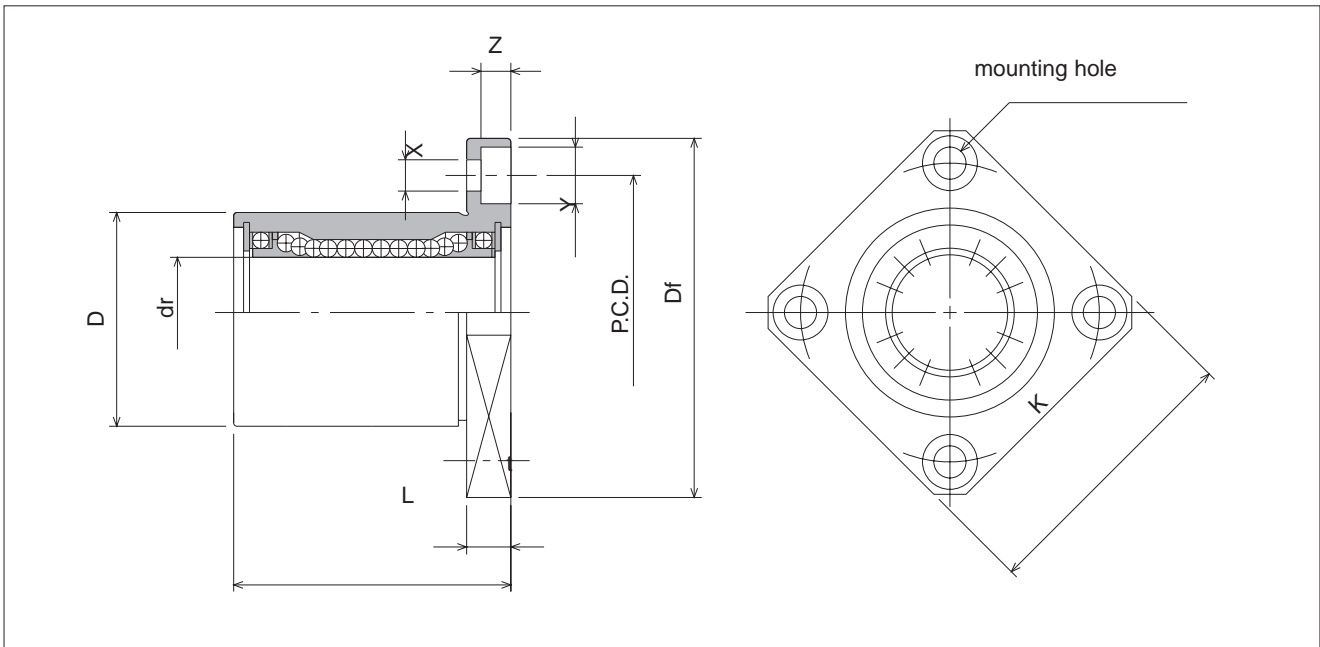

flange			perpendicularity	basic load rating		allowable rotational speed	mass	part number
t	P.C.D	X×Y×Z		dynamic	static			
mm	mm	mm	μm	C	C ₀	rpm	g	
5	20	3.5×6×3.1	12	78	176	300	19	SREK 6
5	24	3.5×6×3.1		137	314	300	27	SREK 8
6	29	4.5×7.5×4.1		157	372	300	36	SREK10
6	32	4.5×7.5×4.1		274	588	300	55	SREK12
6	33	4.5×7.5×4.1		323	686	300	68	SREK13
6	38	4.5×7.5×4.1		451	882	250	93	SREK16
8	43	5.5×9×5.1	15	647	1,180	250	155	SREK20
8	51	5.5×9×5.1		882	1,860	250	270	SREK25
10	60	6.6×11×6.1		1,180	2,650	200	395	SREK30

1N ≅ 0.102kgf

SLIDE ROTARY UNIT

SMA-R TYPE

— Block type —

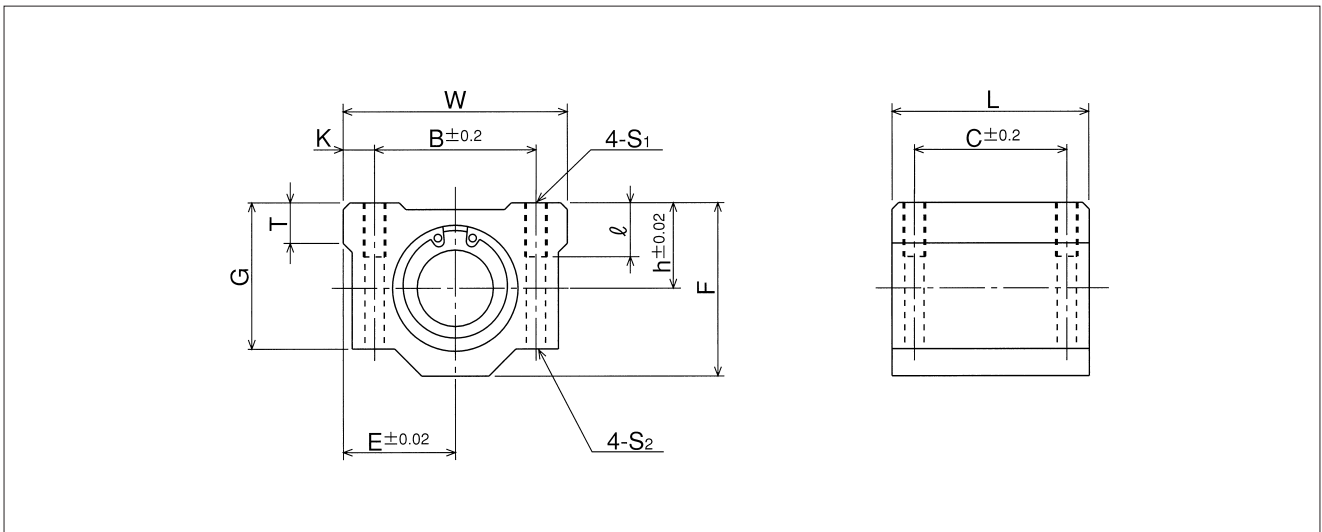
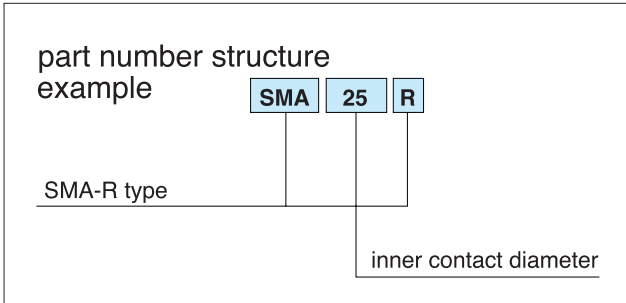

part number	major dimensions															basic load rating		mass
	inner contact diameter		outer dimensions							mounting dimensions						dynamic	static	
	mm	μm	h	E	W	L	F	G	T	B	C	K	S ₁	ℓ	S ₂	C	C ₀	
			mm	mm	mm	mm	mm	mm	mm	mm	mm	mm	mm	mm	N	N	g	
SMA 6R	6		9	15	30	25	18	15	6	20	15	5	M4	8	3.4	78	176	35
SMA 8R	8	+4	11	17	34	30	22	18	6	24	18	5	M4	8	3.4	137	314	50
SMA10R	10	-5	13	20	40	35	26	21	8	28	21	6	M5	12	4.3	157	372	76
SMA12R	12		15	21	42	36	28	24	8	30.5	26	5.75	M5	12	4.3	274	588	100
SMA13R	13	+3	15	22	44	39	30	24.5	8	33	26	5.5	M5	12	4.3	323	686	116
SMA16R	16	-6	19	25	50	44	38.5	32.5	9	36	34	7	M5	12	4.3	451	882	189
SMA20R	20		21	27	54	50	41	35	11	40	40	7	M6	12	5.2	647	1,180	265
SMA25R	25	+3	26	38	76	67	51.5	42	12	54	50	11	M8	18	7	882	1,860	570
SMA30R	30	-7	30	39	78	72	59.5	49	15	58	58	10	M8	18	7	1,180	2,650	755

1N≒0.102kgf

SLIDE ROTARY UNIT SMA-RW TYPE

— Double-Wide Block type —

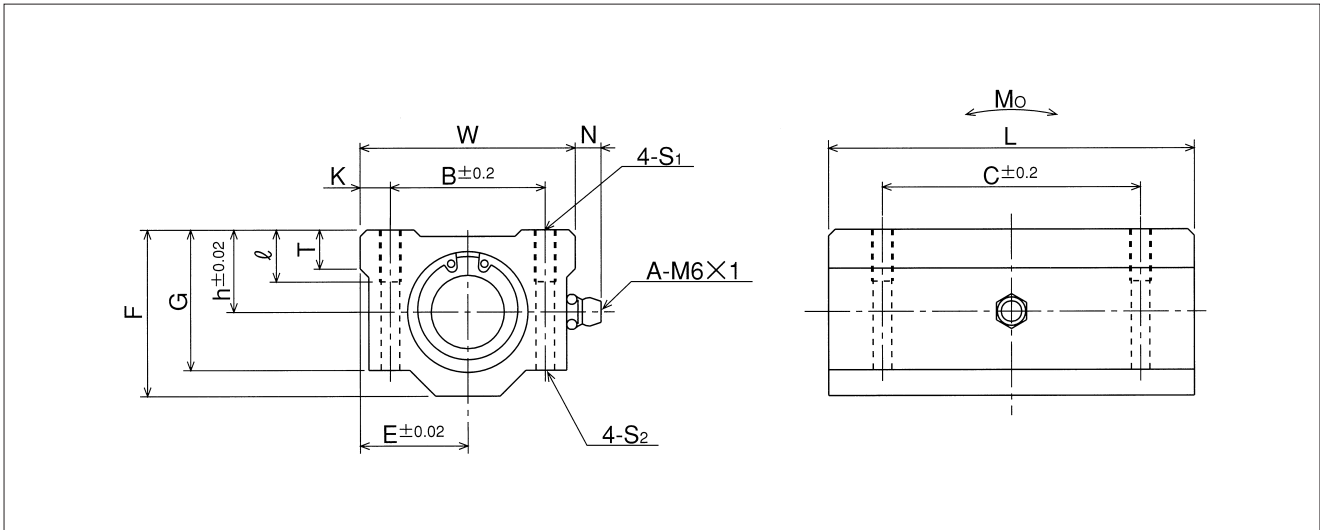
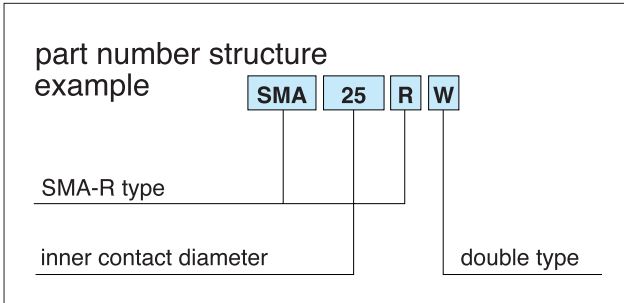

part number	major dimensions															basic load rating		mass	
	inner contact diameter		outer dimensions								mounting dimensions					dynamic	static		
	mm	μm	h	E	W	L	F	G	T	N	B	C	K	S ₁	ℓ	S ₂	C		C ₀
		mm	mm	mm	mm	mm	mm	mm	mm	mm	mm	mm	mm	mm	mm	N	N	g	
SMA 6RW	6		9	15	30	48	18	15	6	7	20	36	5	M4	8	3.4	126	352	64
SMA 8RW	8	+4	11	17	34	58	22	18	6	7	24	42	5	M4	8	3.4	222	628	98
SMA10RW	10	-5	13	20	40	68	26	21	8	7	28	46	6	M5	12	4.3	254	744	148
SMA12RW	12		15	21	42	70	28	24	8	6.5	30.5	50	5.75	M5	12	4.3	444	1,180	201
SMA13RW	13	+3	15	22	44	75	30	24.5	8	6.5	33	50	5.5	M5	12	4.3	523	1,370	232
SMA16RW	16	-6	19	25	50	85	38.5	32.5	9	6	36	60	7	M5	12	4.3	731	1,760	378
SMA20RW	20		21	27	54	96	41	35	11	7	40	70	7	M6	12	5.2	1,050	2,360	590
SMA25RW	25	+3	26	38	76	130	51.5	42	12	4	54	100	11	M8	18	7	1,430	3,720	1,140
SMA30RW	30	-7	30	39	78	140	59.5	49	15	5	58	110	10	M8	18	7	1,910	5,300	1,520

1N≒0.102kgf

SLIDE ROTARY UNIT

AK-R TYPE

— Compact Block type —

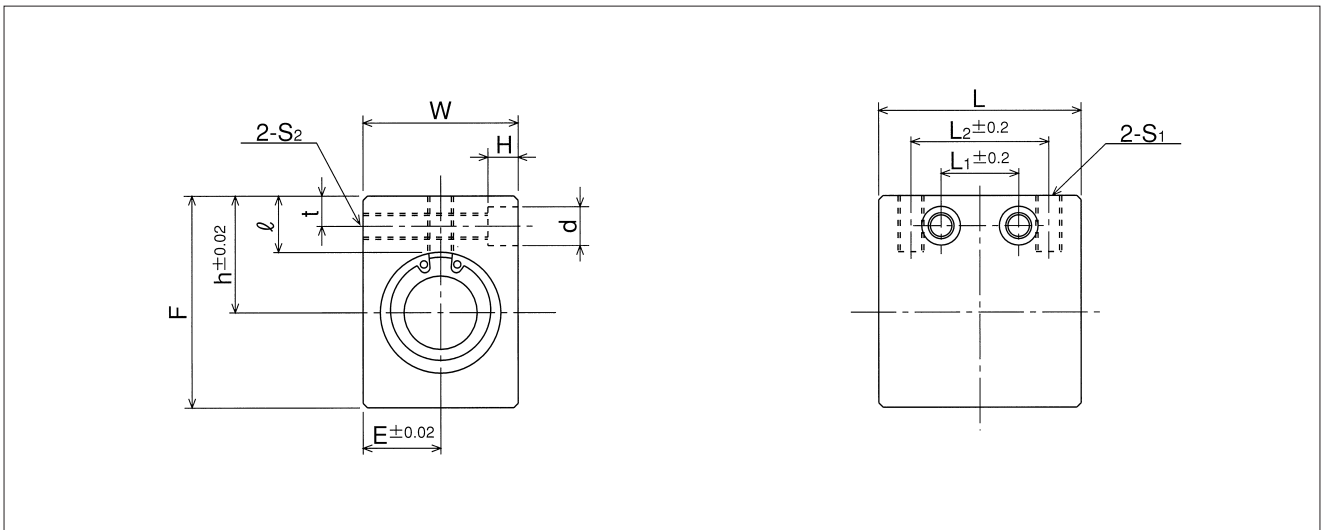
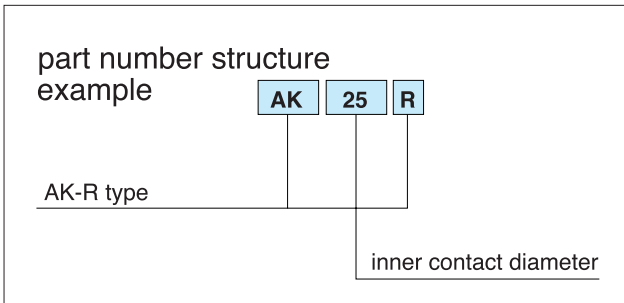

part number	major dimensions															basic load rating		mass
	inner contact diameter		outer dimensions					mounting dimensions								dynamic	static	
	mm	μm	h	E	W	L	F	L ₂	S ₁	ℓ	L ₁	t	S ₂	d	H	C	C ₀	
			mm	mm	mm	mm	mm	mm		mm	mm	mm		mm	mm	N	N	
AK 6R	6		14	8	16	27	22	18	M 4	8	9	5	M 4	6	5	78	176	22
AK 8R	8	+4	16	10	20	32	26	20	M 5	8.5	10	5	M 4	6	5	137	314	38
AK10R	10	-5	19	13	26	39	32	27	M 6	9.5	15	6	M 5	8	6	157	372	64
AK12R	12		20	14	28	40	34	27	M 6	9.5	15	6	M 5	8	6	274	588	88
AK13R	13	+3	25	15	30	42	43	28	M 6	13.5	16	7	M 6	9	7	323	686	128
AK16R	16	-6	27	18	36	47	49	32	M 6	13	18	7	M 6	9	7	451	882	193
AK20R	20		31	21	42	52	54	36	M 8	15	18	8	M 8	11	8	647	1,180	282
AK25R	25	+3	37	26	52	69	65	42	M10	17	22	9	M10	14	10	882	1,860	544
AK30R	30	-7	40	29	58	74	71	44	M10	17.5	22	9	M10	14	10	1,180	2,650	730

1N ≒ 0.102kgf

SLIDE ROTARY UNIT

AK-RW TYPE

— Double-Wide Compact Block type —

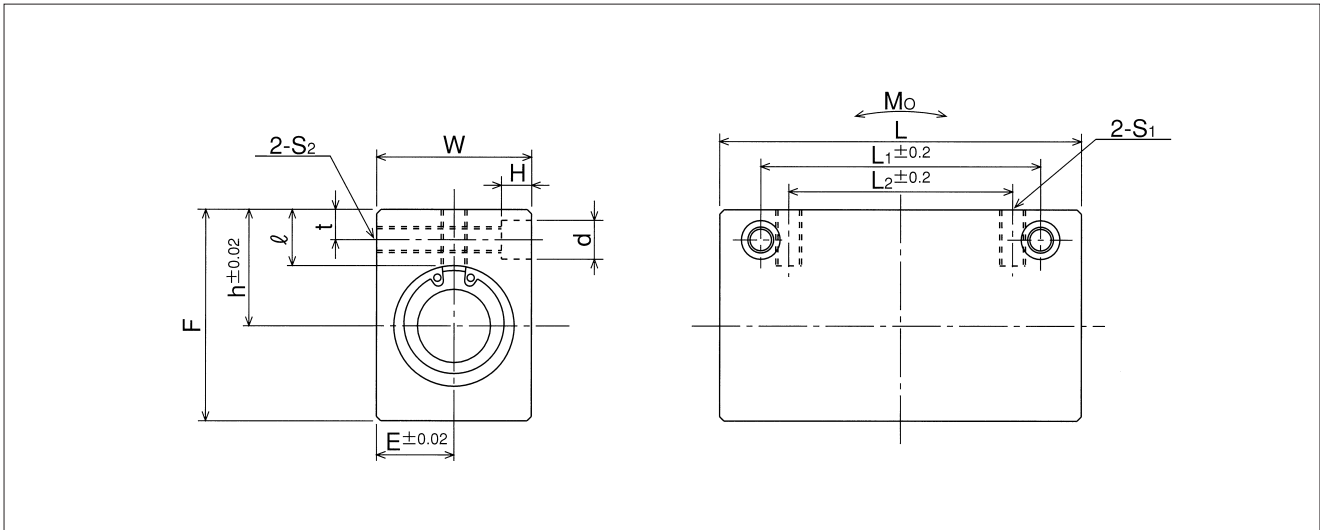
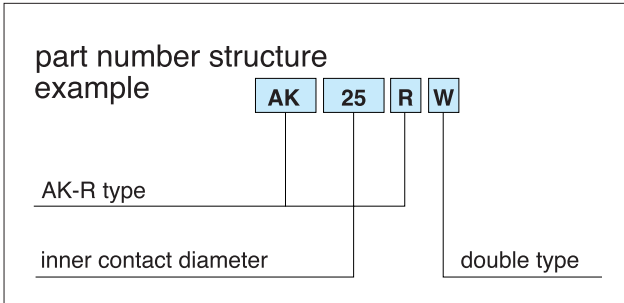

part number	major dimensions															basic load rating		mass
	inner contact diameter		outer dimensions					mounting dimensions								dynamic	static	
	mm	μm	h	E	W	L	F	L ₂	S ₁	ℓ	L ₁	t	S ₂	d	H	C	C ₀	
AK 6RW	6	+4 -5	14	8	16	46	22	20	M 4	8	30	5	M 4	6	5	126	352	41
AK 8RW	8		16	10	20	56	26	30	M 5	8.5	42	5	M 4	6	5	222	628	71
AK10RW	10		19	13	26	68	32	36	M 6	9.5	50	6	M 5	8	6	254	744	118
AK12RW	12	+3 -6	20	14	28	70	34	36	M 6	9.5	50	6	M 5	8	6	444	1,180	164
AK13RW	13		25	15	30	74	43	42	M 6	13.5	55	7	M 6	9	7	523	1,370	240
AK16RW	16		27	18	36	84	49	52	M 6	13	65	7	M 6	9	7	731	1,760	361
AK20RW	20	+3 -7	31	21	42	94	54	58	M 8	15	70	8	M 8	11	8	1,050	2,360	540
AK25RW	25		37	26	52	128	65	80	M10	17	100	9	M10	14	10	1,430	3,720	1,060
AK30RW	30		40	29	58	138	71	90	M10	17.5	110	9	M10	14	10	1,910	5,300	1,424

1N ≒ 0.102kgf

SLIDE ROTARY UNIT

SMP-R TYPE

— Pillow Block type —

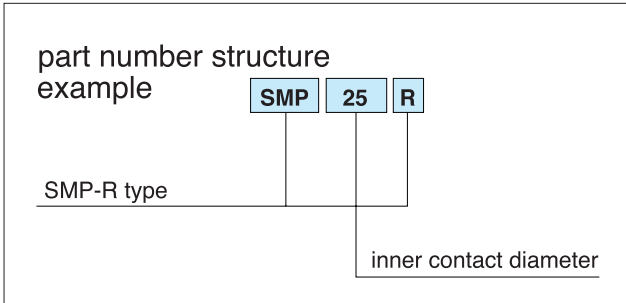

part number	major dimensions								
	inner contact diameter		outer dimensions						
	mm	tolerance μm	h mm	E mm	W mm	L mm	F mm	G mm	M mm
SMP13R	13	+3	25	25	50	32	46	8	36
SMP16R	16	-6	29	27.5	55	37	53	10	40
SMP20R	20	+3 -7	34	32.5	65	42	62	12	48
SMP25R	25		40	38	76	59	73	12	59
SMP30R	30		45	42.5	85	64	84	15	69

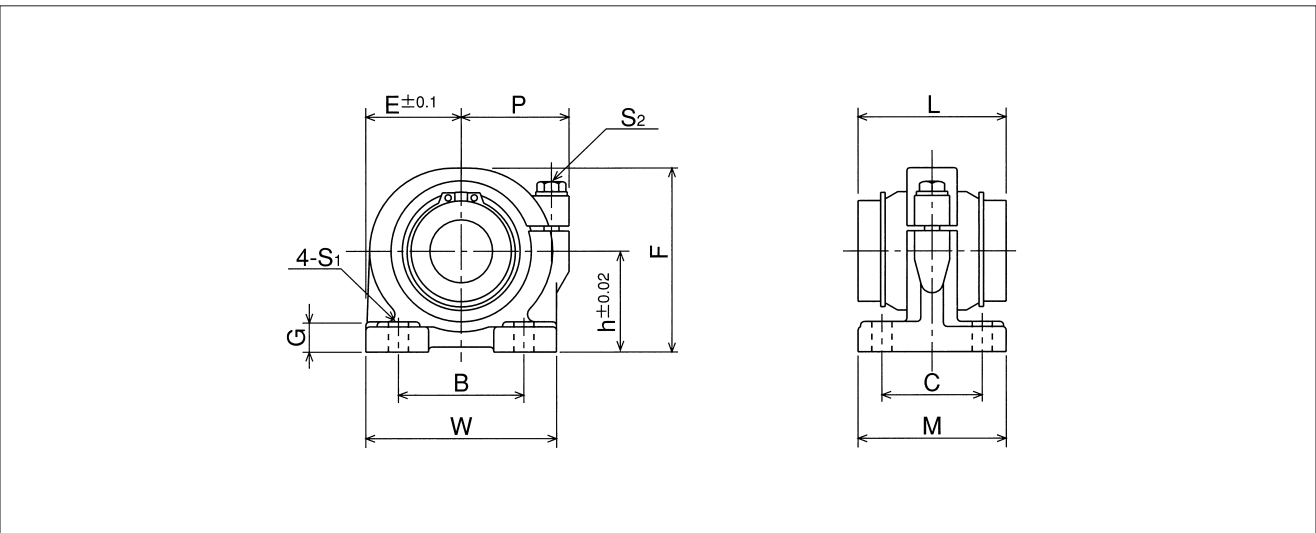

P	mounting dimensions			adjustment bolt size S ₂	basic load rating		mass g	part number
	B	C	S ₁ (bolt size)		dynamic C	static C ₀		
mm	mm	mm	mm		N	N		
30	30	26	7 (M5)	M5	323	686	266	SMP13R
32	35	29	7 (M5)	M5	451	882	369	SMP16R
37	40	35	8 (M6)	M6	647	1,180	690	SMP20R
43	50	40	8 (M6)	M6	882	1,860	970	SMP25R
49	58	46	10 (M8)	M8	1,180	2,650	1,420	SMP30R

1N ≅ 0.102kgf

SLIDE ROTARY BUSH

NB's RK type slide rotary bush is a highly accurate rigid component providing smooth continuous linear and rotational motion. Its structure imposes no constraints on either motion. It is much more compact than a standard slide bush with separate rotational bearing.

STRUCTURE AND ADVANTAGES

The RK type slide rotary bush uses a retainer similar to that used in the SR type stroke bush. This retainer provides the results of smooth rotational motion. The SM type slide bush is also used providing the smooth linear motion. Large ball elements are used enabling the bushing to withstand high loads.

1.A smooth unlimited linear and rotational motion is obtained.

2.There is no need to machine separate housing.

3.High accuracy is ensured for extended period of usage.

4.Its high compatibility eliminates replacement problems.

5.High rigidity enables it to withstand an unbalanced load and high load capacity.

※ For best performance, please select tolerance of h5 for the shaft.

Calculation of Life:

$$L = \left(\frac{f_H \cdot f_T \cdot f_C}{f_w} \cdot \frac{C}{P} \right)^3 \times 50$$

L : travel life (km) f_H : hardness coefficient f_T : temperature coefficient
 f_C : contact coefficient f_w : the loafficient
 C : basic dynamic load rating (N) P : load (N)

※Refer to page Eng. 5 for the coefficients.

※The contact coefficient is used when two or more bushings are used in close contact with each other on the same shaft.

Figure F-6 Structure of RK Slide Rotary Bush

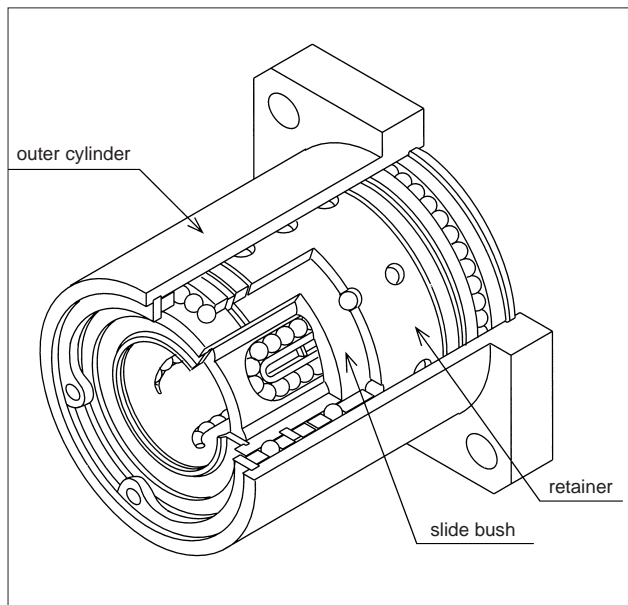

RK TYPE

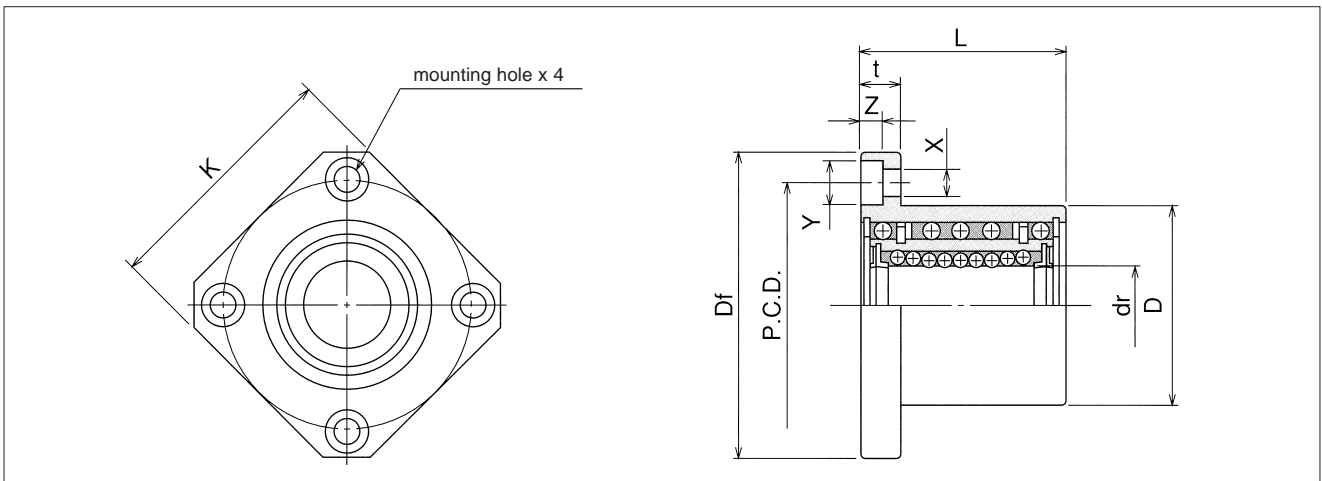
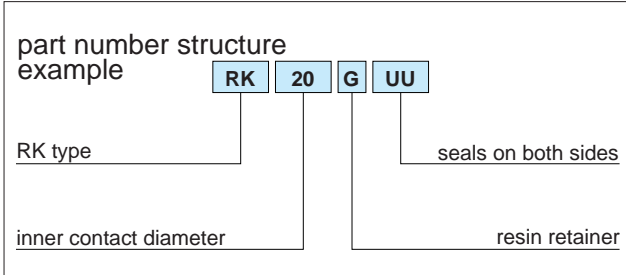

part number	major dimensions										basic load rating		allowable rotational speed rpm	mass g	
	dr		D		L		flange					dynamic			static
	mm	tolerance μm	mm	tolerance μm	mm	tolerance mm	Df mm	K mm	t mm	P.C.D. mm	X×Y×Z mm	C N			Co N
RK12GUU	12	0	32	0	36	±0.3	54	42	8	43	5.5×9×5.1	510	784	500	180
RK16GUU	16	-9	40	0	45		62	50	8	51	5.5×9×5.1	774	1,180	500	280
RK20GUU	20	0	45	-25	50		74	58	10	60	6.6×11×6.1	882	1,370	400	420
RK25GUU	25	0	52	0	67		82	64	10	67	6.6×11×6.1	980	1,570	400	680
RK30GUU	30	-10	60	-30	74		96	75	13	78	9×14×8.1	1,570	2,740	400	990

1N≒0.102kgf