

TOPBALL® PRODUCTS

SLIDE GUIDE

BALL SPLINE
ROTARY BALL SPLINE
STROKE BALL SPLINE

TOPBALL® PRODUCTS

SLIDE BUSH

SLIDE UNIT

STROKE BUSH
SLIDE ROTARY BUSH

SLIDE SHAFT

SLIDE WAY/GONIO WAY
SLIDE TABLE
MINIATURE SLIDE

ACTUATOR

SLIDE SCREW

NB TOPBALL[®] PRODUCTS

NB now offers a new standard in linear motion with TOPBALL. The TOPBALL slide bush is a high performance bushing with three times the load capacity, capable of providing up to 27 times normal travel life of a conventional slide bushing.

TOPBALL is available in a variety of configurations to fit various service conditions. NB's self-aligning TOPBALL can be designed into many different applications such as factory automated equipment, machine tools, industrial machines, electrical equipment, optical and measuring instruments.

In the early stages of NB's development of TOPBALL, careful thought and consideration was given to such factors as quality, cost, performance and interchangeability. The results of these efforts are reflected in the TOPBALL features.

TOPBALL FEATURES

1. Increased Load Capacity:

NB's uniquely designed ground load plate provides circular arch contact to the ball element resulting in a greater dispersion of the load, enabling TOPBALL to provide three times the load capacity of conventional slide bushings.

2. Longer Travel Life:

Dispersed stress on the load plate provides TOPBALL up to 27 times the travel life of conventional slide bushings.

3. Self Aligning Capability:

Load plates are thinner at the ends to provide a pivot point at the center of the plate. The center acts as a fulcrum to compensate for any slight misalignment between the shaft and the housing bore that might be caused by inaccurate machining, mounting errors or shaft deflection.

Figure C-1 Illustrating circular arch design and ground surface raceway

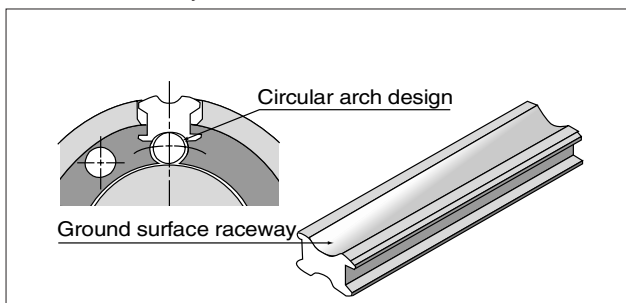

4. Floating Integral Wiper Seal:

NB's unique floating seal design allows for self-alignment while maintaining equal and constant contact to the shaft. Seals do not add to the overall length of the bushing allowing for more compact designs.

5. Clearance Adjustable:

TOPBALL load plates are designed to "float" in the outer sleeve which allows for clearance between the ball elements and shaft to best suit application requirements.







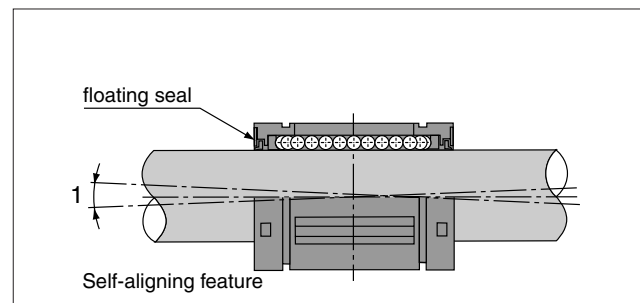









6. Cost Effectiveness:

TOPBALL's higher load capability and longer travel life enables the use of smaller components such as bushings, housings and shafts, reducing material cost and the overall cost of the system. Longer travel life also extends replacement periods and reduce maintenance cost.

Figure C-2 Illustrating floating seal and self-aligning feature



TYPES

		Metric series		Inch series	
TOPBALL	closed type	TK  P.C-8	TW  P.C-10		
	open type	TK-OP  P.C-8	TW-OP  P.C-10		
TOPBALL unit	closed type	TKA  P.C-12	TKA-W  P.C-13	TWA  P.C-18	TWA-W  P.C-19
	adjustable type	/		TWJ  P.C-20	TWJ-W  P.C-21
	open type	TKE  P.C-14	TKE-W  P.C-15	/	
	adjustable-open type	TKD  P.C-16	TKD-W  P.C-17	TWD  P.C-22	TWD-W  P.C-23

RATED LIFE

The life of a slide bush can be easily calculated with the load rating of the bush, shaft hardness and applicable load. However, in many cases, slide bushing failure may be caused by improper design of peripherals, including the shaft and housing, inappropriate mounting or improper operation. Serious consideration of these peripheral factors, in addition to load rating, are highly recommended when designing a slide bush application.

Basic Dynamic Load Rating and Life Expectancy:

The basic dynamic load rating is the load which allows a rating life of 50km, without changing its magnitude and direction. The rating life can be obtained from the following equation.

$$L = \left(\frac{C}{P}\right)^3 \cdot 50 \quad \text{Equation (1)}$$

L : travel life (km)
 C : basic dynamic load rating (N)
 P : load (N)

Figure C-3 shows the relationship between rating life (L) and load ratio(C/P). In the practical use of a bushing, other factors that affect the life, such as shaft hardness and load condition should be considered. The equation for calculating bushing life considering these additional factors is:

$$L = \left(\frac{f_H}{f_W} \cdot \frac{C}{P}\right)^3 \cdot 50 \quad \text{Equation (2)}$$

f_H : hardness coefficient (See Figure C-4)
 f_W : load coefficient (See Table C-1)

Life time can be calculated by obtaining the travelling distance per unit of time as follows:

$$L_h = \frac{L \cdot 10^3}{2 \cdot L_s \cdot N1 \cdot 60} \quad \text{Equation (3)}$$

L_h : life time (hr)
 L_s : stroke length (m)
 N1 : stroke frequency per min. (cpm)
 L : travel life (km)

Figure C-3: Slide Bush Life

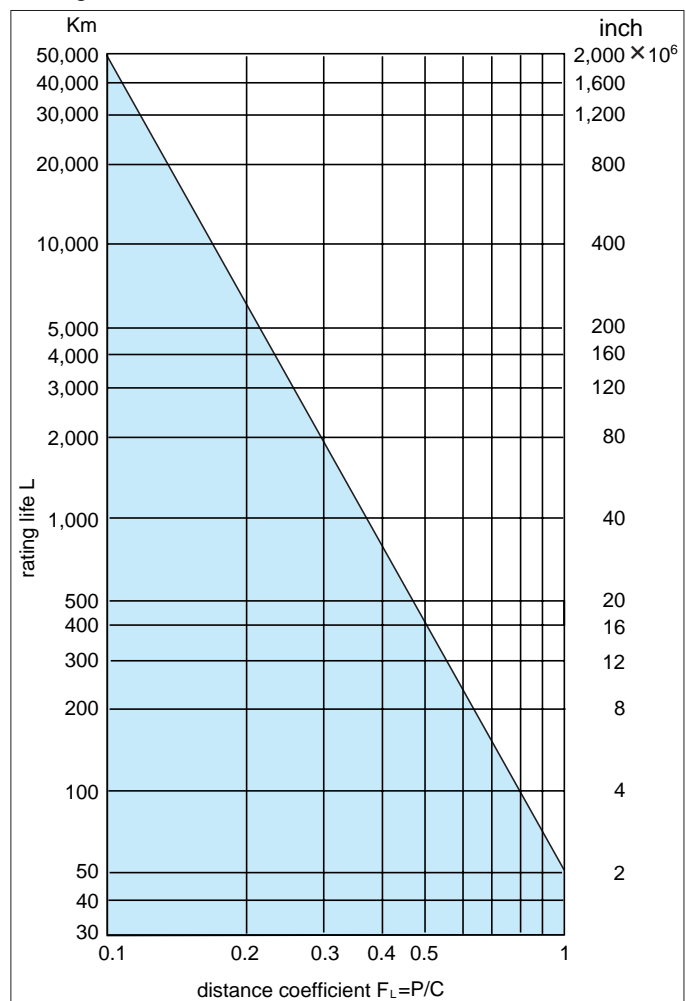

Load coefficient (fw):

When calculating the bush load, it is necessary to accurately obtain weight, inertial force based on speed, moment load and each transition as time passes. However, it is difficult to calculate those values accurately because reciprocating motion involves the repetition of starts and stops as well as vibration and impact. A more practical approach is to obtain the load coefficient by taking the actual operating conditions into account.

Table C-1: Load Coefficient

OPERATING CONDITIONS	fw
operation at low speed (15m/min. or less) without impulsive shock from outside	1.0-1.5
operation at intermediate speed (60m/min.or less) without impulsive shock	1.5-2.0
operation at high speed (over 60m/min.) with impulsive shock	2.0-3.5

Hardness Coefficient (fH):

The shaft must be hardened to over 58HRC when a slide bush is used. If not properly hardened, permissible load is lowered and the life of the bushing will be shortened.

Figure C-4: Hardness coefficient

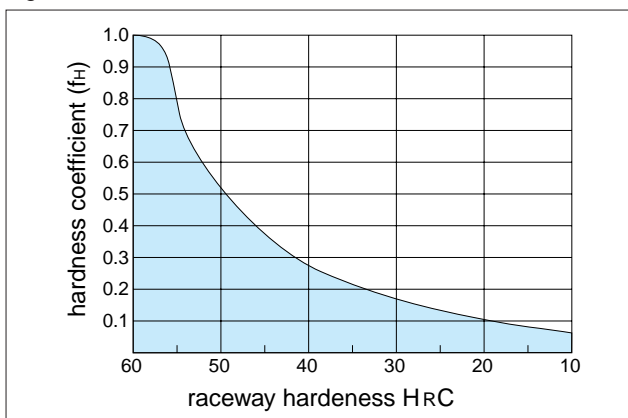

Examples of Calculations:

(1) Life expectancy when NB's TOPBALL TK 25 is used under the following conditions:

- Load per bush: 668N
- Stroke length: 0.2m
- Rate of cycles/min: 35
- Shaft hardness: 60HRC

From the basic dynamic load of TK25 is 3780N. hardness coefficient(fH) is 1.0, and the operating speed can be calculated as 0.014km/min. Therefore, the load coefficient(fw) is considered as 1.0.

Using Equation (1) (Page C-4)

$$L = \left(\frac{3780}{668}\right)^3 \cdot 50 = 9,060 \text{ km}$$

Using Equation (3) (Page C-4)

$$L_h = \frac{9,060 \cdot 10^3}{2 \cdot 0.2 \cdot 35 \cdot 60} = 10,800 \text{ hours}$$

(2) Selection of size for the application

- Expected life: 15,000 hours
- Number of bushings in the carriage: 4
- Gross weight on the carriage: 668N
- Stroke length: 0.0009km
- Traveling speed: 0.03km/min.
- Shaft hardness: 60-64HRC

The life expected in traveling distance is:

$$L = 15,000 \cdot 0.03 \cdot 60 = 27,000 \text{ km} (2.7 \times 10^4)$$

From Equation (2)

$$C = \sqrt[3]{\frac{27000}{50} \cdot \left(\frac{fw}{fH}\right)} \cdot P = 2,040 \text{ N}$$

Note that: fH=1.0, fw=1.5, P=668/4=167N

As a result, the TOPBALL that is able to handle this load is: TK20.

Basic Static Load Rating:

If a slide bush is loaded when it is in a stationary condition or working at a low speed, a permanent elastic deformation is formed on the rolling element. The deformation prevents smooth movement of the bushing. To eliminate this possibility, the basic static load rating must not be exceeded.

Relation Between Ball Circuits and Load Rating:

The load rating of a slide bush varies according to the loaded position on the circumference. The value in the dimensional table indicates the lowest load rating with the load placed on top of one ball circuit. If the slide bush is used with two ball circuits loaded uniformly, the value will be greater. Table C-2 shows the load ratio for the number of ball circuits in each case.

Clearance and Fit:

An appropriate clearance between the slide bush and shaft is required in TOPBALL operation. Inadequate clearance may cause early failure and/or poor, rough movement. Proper clearance is determined by shaft diameter and housing bore. Table C-3 and C-4 shows NB's recommended tolerances of the shaft and housing bore in order to maintain the appropriate clearance.

Table C-3: Recommended Tolerance for Shaft Dia. and Housing Bore

part number	shaft dia.		housing bore	
	dr mm	tol. (h6) μm	D mm	tol. (H7) μm
TK10	10	0	19	+21
TK12	12		22	
TK16	16	-11	26	0
TK20	20	0	32	+25
TK25	25		40	
TK30	30	-13	47	0
TK40	40	0/-16	62	+30/0

Table C-2: Optional Load Positions

NUMBER OF ROWS	4	5	6
Co (LOAD RATING SPECIFIED ON THE TABLE)			
Comax (MAXIMUM LOAD RATING)			
LOAD RATIO Comax/Co	1,414	1,463	1,280

Anti-Corrosive Type:

A special TOPBALL is also available for corrosive applications. Specify with a suffix "-SK" for either bushing or slide unit requiring our anti-corrosive type TOPBALL. The load plates are electroless nickel plated and use Stainless Steel ball elements. For "-SK" slide units, all hardware components are of anti-corrosive properties.

Table C-4: Recommended Tolerance for Shaft Dia. and Housing Bore

size	shaft dia.		housing bore.	
	dr inch	tol. (g6) inch	D inch	tol. (H7) inch
TW 3	.1875	-.0002 -.0006	.3750	+.0005 0
TW 4	.2500		.5000	+.0007 0
TW 6	.3750	-.0002 -.0007	.6250	+.0008 0
TW 8	.5000		.8750	
TW10	.6250	-.0003 -.0008	1.1250	+.0010 0
TW12	.7500		1.2500	
TW16	1.0000	-.0004 -.0010	1.5625	+.0012 0
TW20	1.2500		2.0000	
TW24	1.5000	-.0004 -.0012	2.3750	0
TW32	2.0000		3.0000	

Shaft and Housing:

To optimize **NB** TOPBALL performance, high precision shafts and housings are required.

1. Shaft: Dimensional tolerance, surface finish and hardness greatly affect the traveling performance of the TOPBALL. The shaft must be manufactured to the following tolerances.

- A. A surface finish of 0.4Ra or less.
- B. Hardness of 60 HRC or more. Hardness less than 60 HRC decreases the life considerably and reduces the permissible load.
- C. The correct tolerance of the shaft diameter is recommended on Table C-3 and C-4 (Page C-6).

The **NB** Slide Shaft is an ideal component manufactured to these specifications. For details, please refer to Page G-2 to G-21.

2. Housing: There are a wide range of designs and manufacturing techniques for mounted housings. **NB** pre-engineered slide units are also available. For proper fit refer to Table C-3 and C-4 (Page C-6).

Mounting:

TOPBALL is designed to be press fitted into the housing bore. When inserting bushing, however, don't apply excess force nor shock load which may cause permanent damage.

Examples of Mounting

Figures C-5 to C-8 illustrate mounting methods as examples.

Figure C-5 Use of holding plates

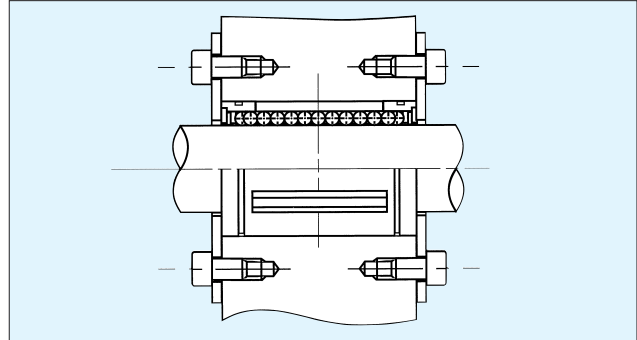

Figure C-6 Adjustable type housing

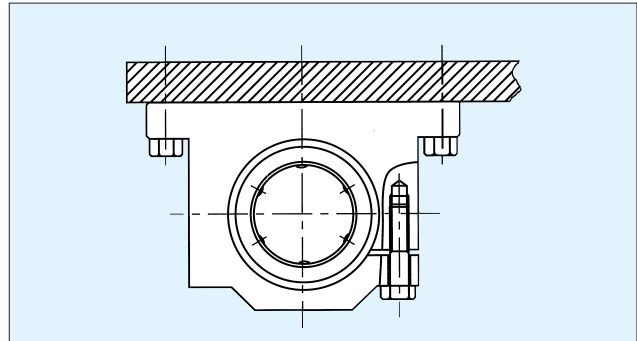

Figure C-7 Use of external retaining rings

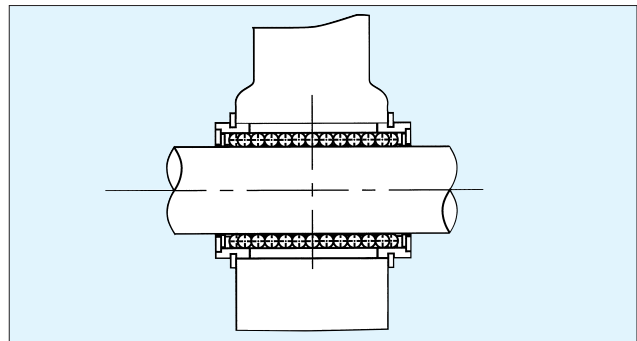
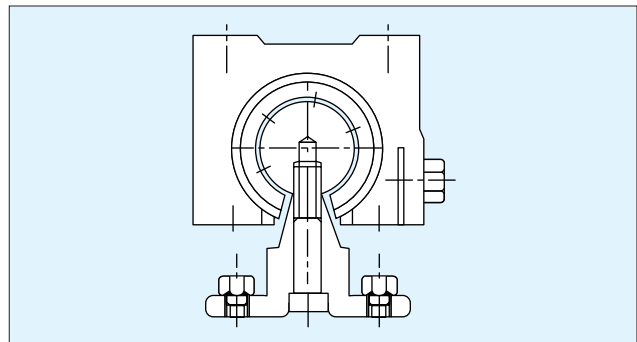
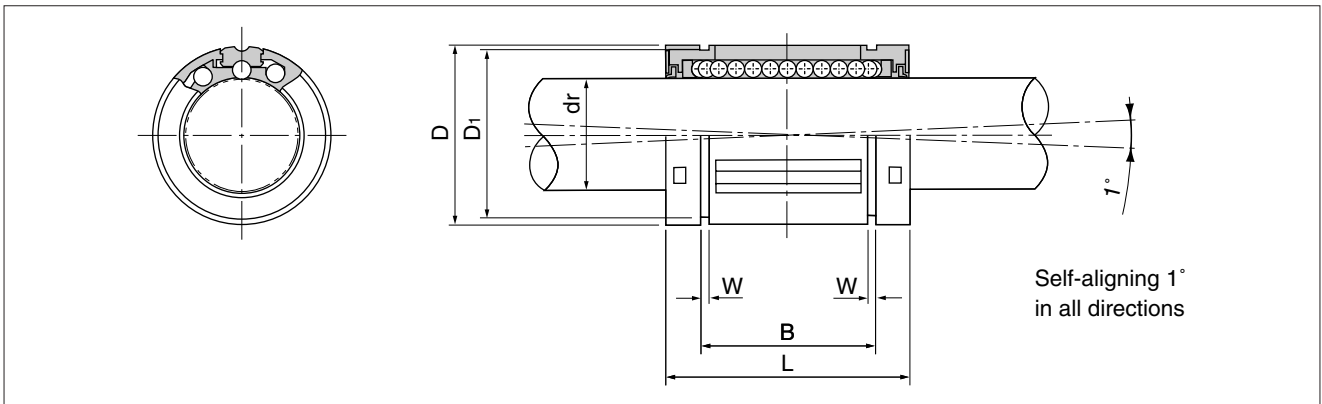
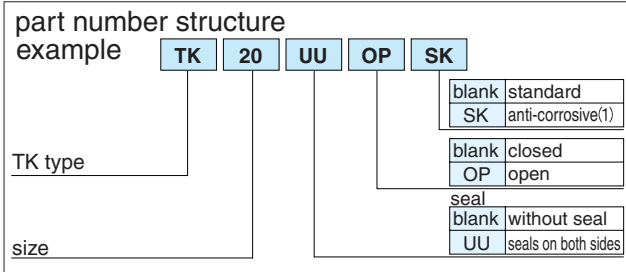

Figure C-8 Open type housing



TK TYPE

– TOPBALL Metric Type –



part number										
closed type			open type			dr		D	L	
	no. of ball circuits	mass g		no. of ball circuits	mass g	mm	tolerance* μm		mm	tolerance mm
TK10	5	14	—	—	—	10	+ 8	19	29	±0.2
TK12	5	21	TK12-OP	4	17	12	0	22	32	
TK16	5	43	TK16-OP	4	35	16	+ 9	26	36	
TK20	6	58	TK20-OP	5	48	20	- 1	32	45	
TK25	6	123	TK25-OP	5	103	25	+11	40	58	
TK30	6	216	TK30-OP	5	177	30	- 1	47	68	
TK40	6	333	TK40-OP	5	275	40	+13/-2	62	80	

* Based on nominal housing bore

(1) For anti-corrosion the load plates are electroless nickel plated with Stainless Steel ball elements.

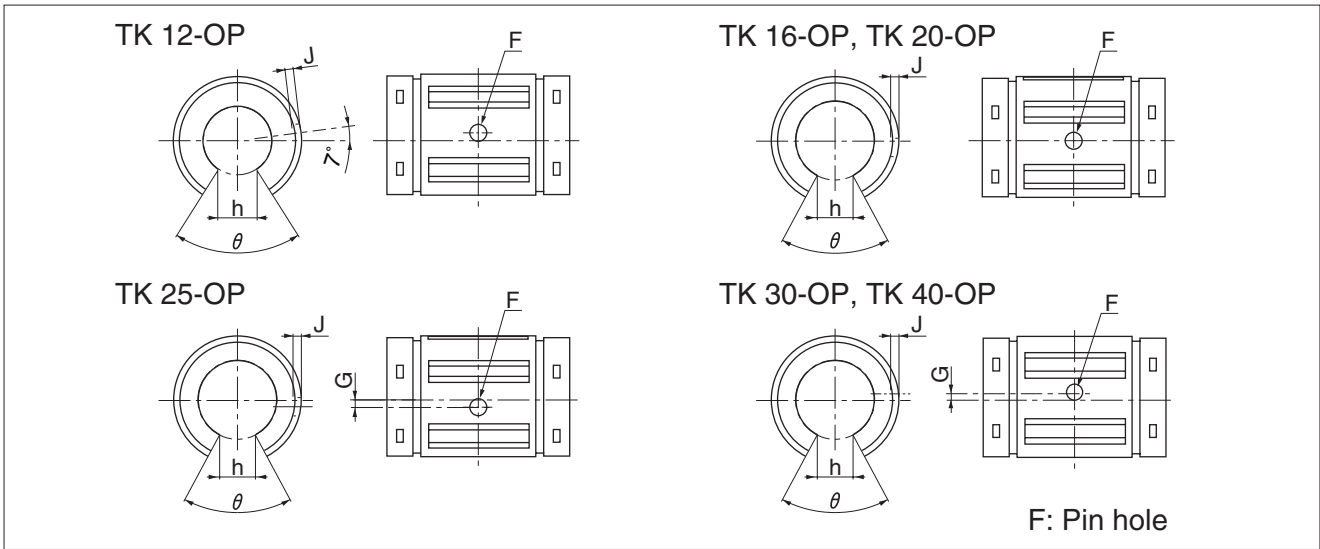

major dimensions									basic load rating		nominal shaft diameter mm
mm	B tolerance	W mm	D ₁ mm	open type					dynamic C	static C ₀	
	mm			h mm	θ	F ^{H11} mm	G mm	J mm	N	N	
22.0	0 -0.2	1.3	18	—	—	3	—	—	750	935	10
22.9		1.3	21	6.5	66°		—	0.7	1020	1290	12
24.9		1.3	24.9	9	68°		—	1.0	1250	1550	16
31.5		1.6	30.3	9	55°		—	1.0	2090	2630	20
44.1	0 -0.3	1.85	37.5	11.5	57°		1.5	1.5	3780	4720	25
52.1		1.85	44.5	14	57°		2	2.2	5470	6810	30
60.6		2.15	59	19.5	56°		1.5	2.7	6590	8230	40

1N ≙ 0.102kgf

TW TYPE

– TOPBALL Inch Type –

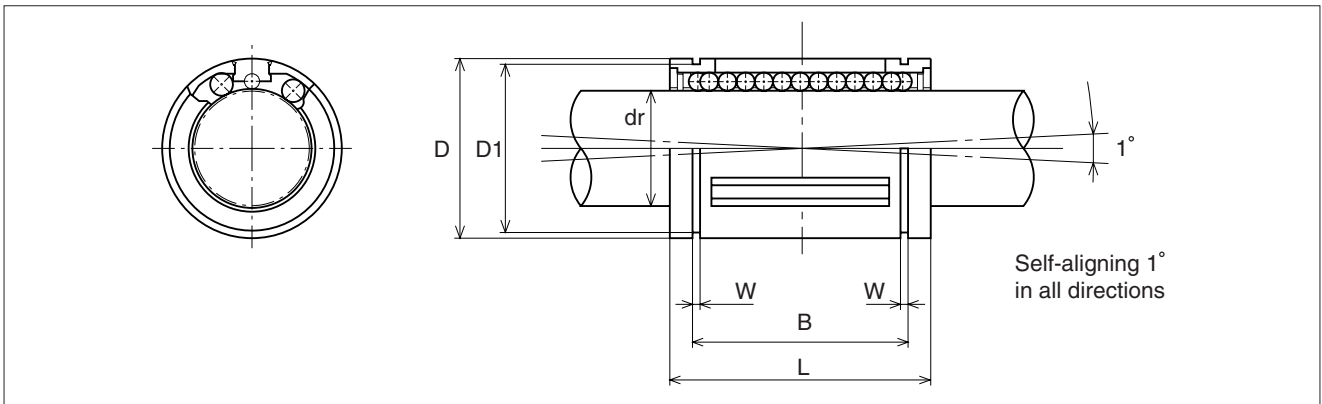
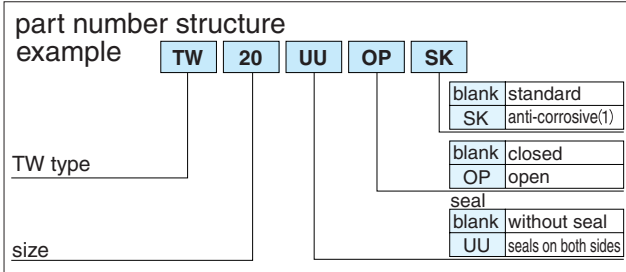

TW	part number					major dimensions				
	closed type		open type			dr	D	L		
	no.of ball circuits	mass lbs	no.of ball circuits	mass lbs	tolerance*			inch	tolerance	
inch	inch	inch	inch	inch	inch	inch	inch	inch		
TW 3	4	.004	—	—	—	.1875	0 -.0005	.3750	.562	±.008
TW 4	4	.009	—	—	—	.2500		.5000	.750	0
TW 6	4	.014	—	—	—	.3750		.6250	.875	-.015
TW 8	4	.043	TW 8-OP	3	.033	.5000		.8750	1.250	0 -.020
TW 10	5	.103	TW 10-OP	4	.083	.6250		1.1250	1.500	
TW 12	6	.123	TW 12-OP	5	.102	.7500		1.2500	1.625	
TW 16	6	.265	TW 16-OP	5	.220	1.0000	1.5625	2.250	0 -.025	
TW 20	6	.485	TW 20-OP	5	.419	1.2500	2.0000	2.625		
TW 24	6	.750	TW 24-OP	5	.639	1.5000	2.3750	3.000		0/-.030
TW 32	6	1.411	TW 32-OP	5	1.168	2.0000	0/-.0008	3.0000	4.000	0/-.040

* Based on nominal housing bore.

(1) For anti-corrosion the load plates are electroless nickel plated with Stainless Steel ball elements.

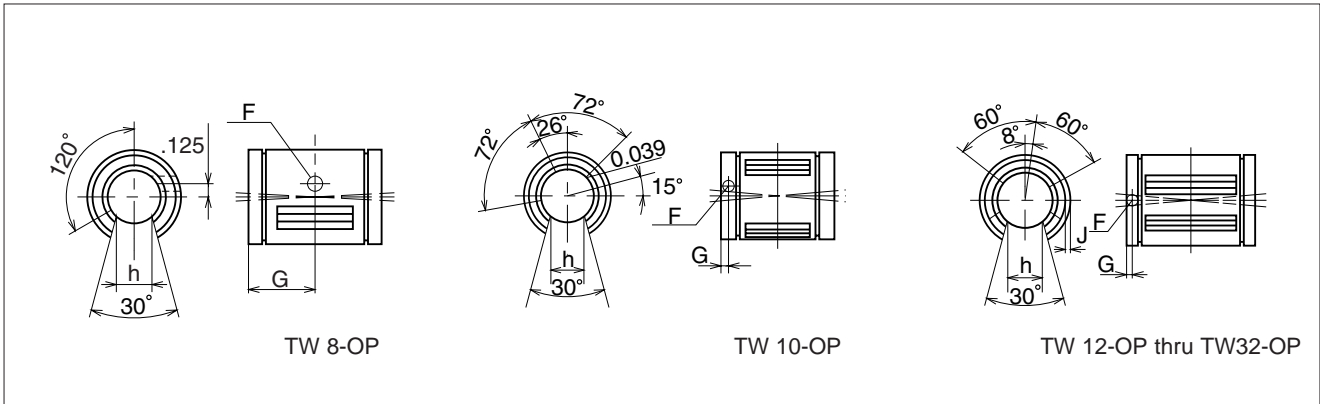

B	tolerance	W	D ₁	open type				basic load rating		nominal shaft diameter
				h	F	G	J	dynamic C	static Co	
inch	inch	inch	inch	inch	inch	inch	inch	lbs	lbs	inch
—	—	—	—	—	—	—	—	35	47	3/16
.515	0	.0390	.4687	—	—	—	—	60	80	1/4
.703	-.015	.0390	.5880	—	—	—	—	95	120	3/8
1.032	0 -.020	.0459	.8209	.313	.136	.6250	through	230	290	1/2
1.112		.0559	1.0590	.375	.105	.1250	.0390	400	500	5/8
1.272		.0559	1.1760	.438	.136	.1250	.0590	470	590	3/4
1.886		.0679	1.4687	.563	.136	.1250	.0470	850	1,060	1
2.011	0/-.025	.0679	1.8859	.625	.201	.1875	.0900	1,230	1,530	1-1/4
2.422	0/-.030	.0859	2.2389	.750	.201	.1875	.0900	1,480	1,850	1-1/2
3.206	0/-.040	.1029	2.8379	1.000	.265	.3125	through	2,430	3,040	2

1 inch = 25.4 mm
 1 lbs ≅ 0.454 kg
 1 lbs ≅ 4.448 N

TKA TYPE

– Block Type –

(Metric Series)

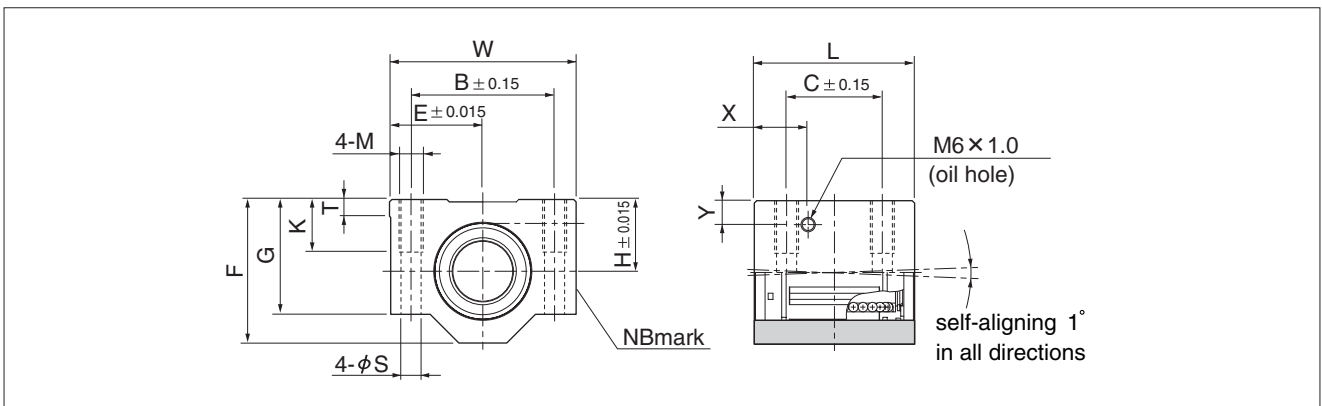
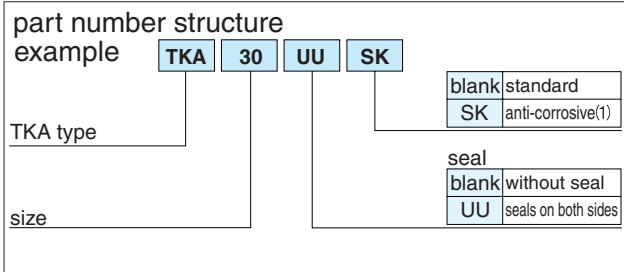

part number	nom. shaft dia. mm	major dimensions									mounting dimensions					load rating		mass g
		H	E	W	L	F	G	T	X	Y	B	C	M	K	S	dynamic C N	static Co N	
TKA10UU	10	16	20	40	36	31.5	25	5	—	—	29	20	M 5	11	4.3	750	935	90
TKA12UU	12	18	21.5	43	39	35	28	5	—	—	32	23	M 5	11	4.3	1020	1290	116
TKA16UU	16	22	26.5	53	43	42	35	5	—	—	40	26	M 6	13	5.3	1250	1550	205
TKA20UU	20	25	30	60	54	50	42	5	19	9	45	32	M 8	18	6.6	2090	2630	326
TKA25UU	25	30	39	78	67	60	48	7	22.5	10	60	40	M10	22	8.4	3780	4720	624
TKA30UU	30	35	43.5	87	79	70	58	8	26	11.5	68	45	M10	22	8.4	5470	6810	980
TKA40UU	40	45	54	108	91	90	72	10	26.5	14	86	58	M12	26	10.5	6590	8230	1670

recommended shaft tolerance is h6

1N≒0.102kgf

(1) For anti-corrosion the load plates are electroless nickel plated with Stainless Steel ball elements.

TKA-W TYPE

— Double-Wide Block Type —

(Metric Series)

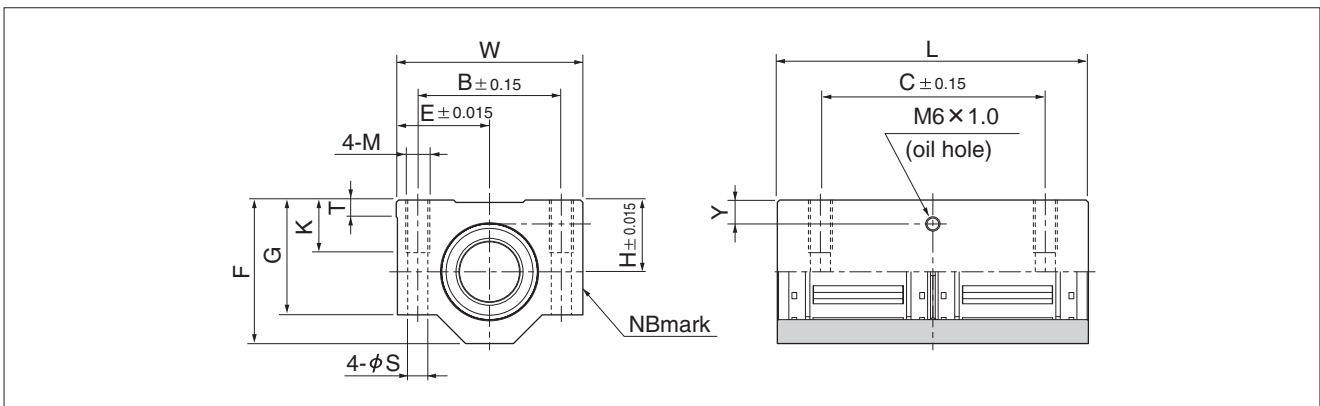
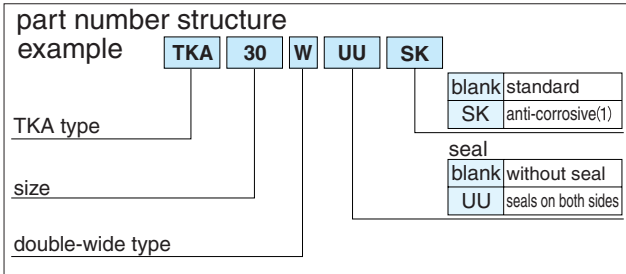
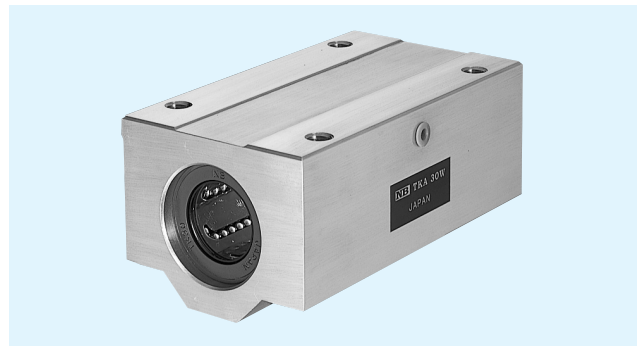

part number	nom. shaft dia. mm	major dimensions							mounting dimensions							load rating		mass g
		H	E	W	L	F	G	T	Y	B	C	M	K	S	dynamic C N	static Co N		
		mm	mm	mm	mm	mm	mm	mm	mm	mm	mm	mm	mm	mm	mm	mm		
TKA10WUU	10	16	20	40	70	31.5	25	5	7	29	52	M 5	11	4.3	1215	1870	175	
TKA12WUU	12	18	21.5	43	76	35	28	5	7.5	32	56	M 5	11	4.3	1652	2580	227	
TKA16WUU	16	22	26.5	53	84	42	35	5	9.5	40	64	M 6	13	5.3	2025	3100	390	
TKA20WUU	20	25	30	60	104	50	42	5	9	45	76	M 8	18	6.6	3390	5260	630	
TKA25WUU	25	30	39	78	130	60	48	7	10	60	94	M10	22	8.4	6120	9440	1210	
TKA30WUU	30	35	43.5	87	152	70	58	8	11.5	68	106	M10	22	8.4	8860	13620	1880	
TKA40WUU	40	45	54	108	176	90	72	10	14	86	124	M12	26	10.5	10680	16460	3280	

(1) For anti-corrosion the load plates are electroless nickel plated with Stainless Steel ball elements.

1N≒0.102kgf

TKE TYPE

– Open Block Type –

(Metric Series)

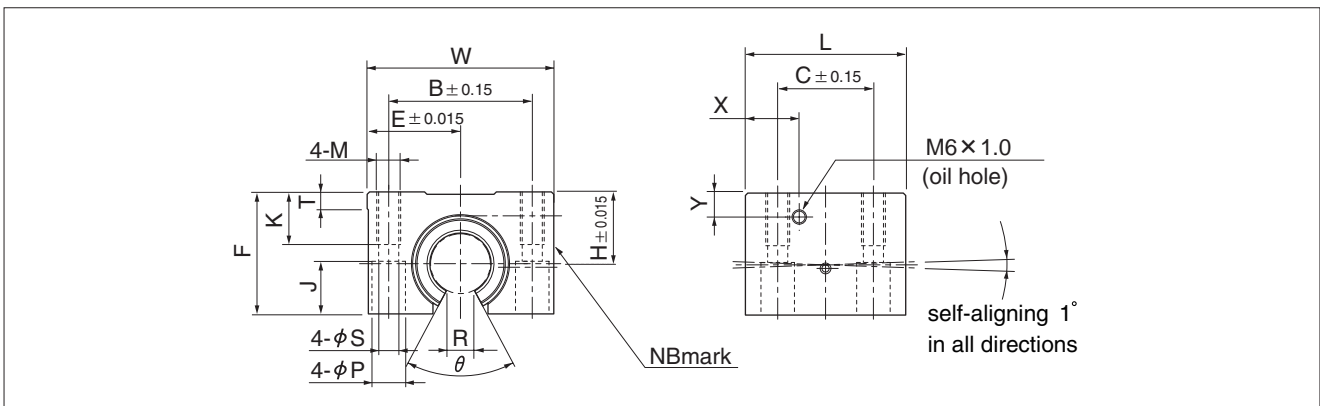
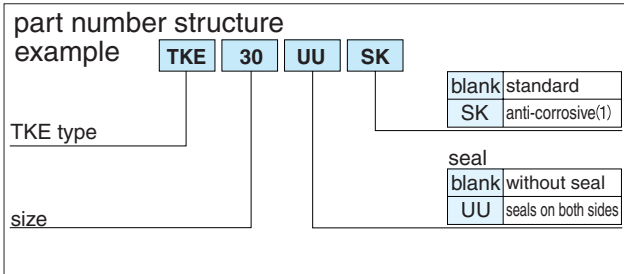

part number	nom. shaft dia. mm	major dimensions									mounting dimensions								load rating		mass g
		H	E	W	L	F	T	R	θ	X	Y	B	C	M	K	S	P	J	dynamic C N	static Co N	
TKE12UU	12	18	21.5	43	39	28	5	6.5	66°	14.5	7.5	32	23	M 5	11	4.3	8	4.5	1020	1290	99
TKE16UU	16	22	26.5	53	43	35	5	9	68°	15.5	9.5	40	26	M 6	13	5.3	9.5	5.5	1250	1550	175
TKE20UU	20	25	30	60	54	42	5	9	55°	19	9	45	32	M 8	18	6.6	11	6.5	2090	2630	275
TKE25UU	25	30	39	78	67	51	7	11.5	57°	22.5	10	60	40	M10	22	8.4	14	8.6	3780	4720	558
TKE30UU	30	35	43.5	87	79	60	8	14	57°	26	11.5	68	45	M10	22	8.4	14	8.6	5470	6810	860
TKE40UU	40	45	54	108	91	77	10	19.5	56°	26.5	14	86	58	M12	26	10.5	17.5	10.8	6590	8230	1490

(1) For anti-corrosion the load plates are electroless nickel plated with Stainless Steel ball elements.

1N≒0.102kgf

TKE-W TYPE

– Double-Wide Open Block Type –
(Metric Series)

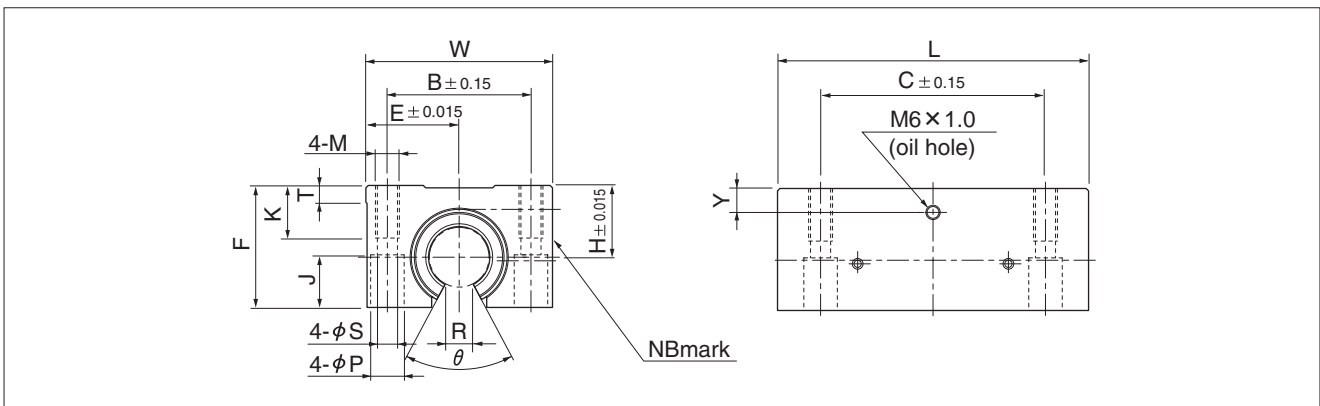
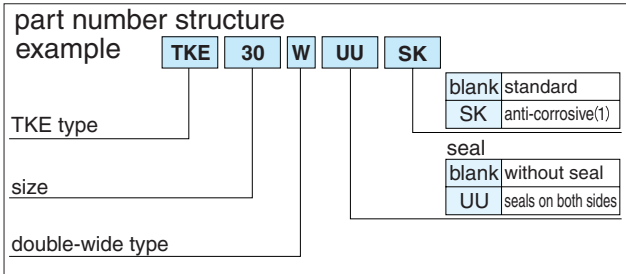

part number	nom. shaft dia. mm	major dimensions									mounting dimensions							load rating		mass g
		H	E	W	L	F	T	R	θ	Y	B	C	M	K	S	P	J	dynamic C N	static Co N	
		mm	mm	mm	mm	mm	mm	mm	mm	mm	mm	mm	mm	mm	mm	mm	mm			
TKE12WUU	12	18	21.5	43	76	28	5	6.5	66°	7.5	32	56	M 5	11	4.3	8	4.5	1652	2580	190
TKE16WUU	16	22	26.5	53	84	35	5	9	68°	9.5	40	64	M 6	13	5.3	9.5	5.5	2025	3100	312
TKE20WUU	20	25	30	60	104	42	5	9	55°	9	45	76	M 8	18	6.6	11	6.5	3390	5260	505
TKE25WUU	25	30	39	78	130	51	7	11.5	57°	10	60	94	M10	22	8.4	14	8.6	6120	9440	1050
TKE30WUU	30	35	43.5	87	152	60	8	14	57°	11.5	68	106	M10	22	8.4	14	8.6	8860	13620	1630
TKE40WUU	40	45	54	108	176	77	10	19.5	56°	14	86	124	M12	26	10.5	17.5	10.8	10680	16460	2880

(1) For anti-corrosion the load plates are electroless nickel plated with Stainless Steel ball elements.

1N≒0.102kgf

TKD TYPE

– Clearance Adjustable Open Block Type –
(Metric Series)

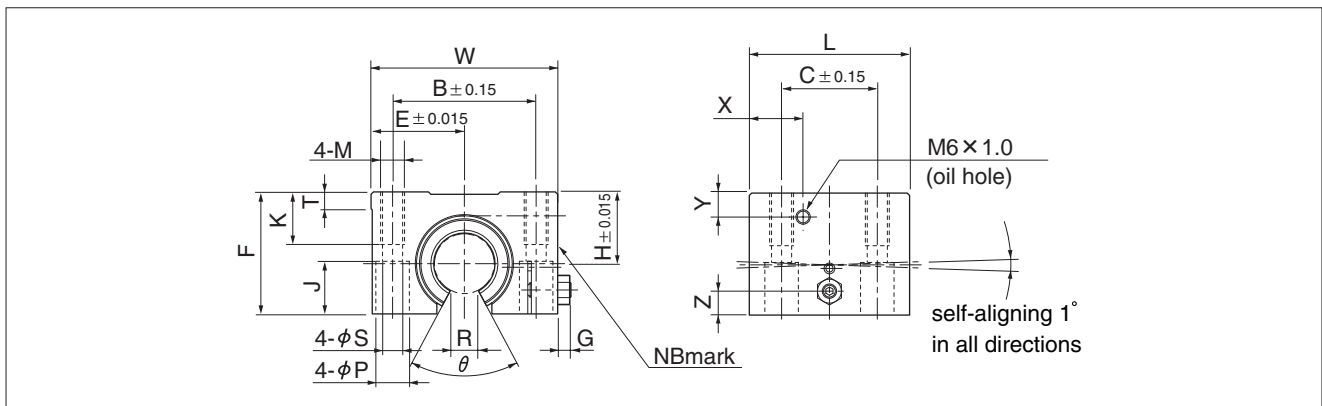
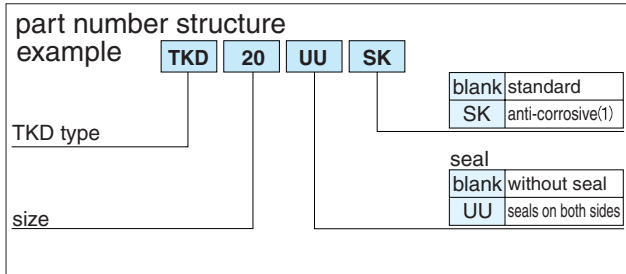
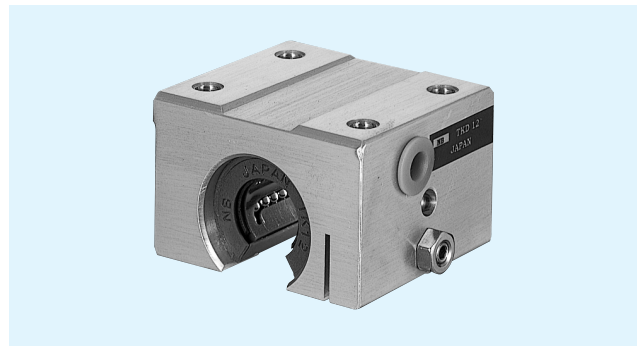

part number	nom. shaft dia. mm	major dimensions										mounting dimensions							load rating		mass g		
		H	E	W	L	F	G	Z	T	R	θ	X	Y	B	C	M	K	S	P	J		dynamic C N	static Co N
		mm	mm	mm	mm	mm	mm	mm	mm	mm	mm	mm	mm	mm	mm	mm	mm	mm	mm	mm		mm	mm
TKD12UU	12	18	21.5	43	39	28	3.2	5	5	6.5	66°	14.5	7.5	32	23	M 5	11	4.3	8	11.5	1020	1290	99
TKD16UU	16	22	26.5	53	43	35	3.2	6	5	9	68°	15.5	9.5	40	26	M 6	13	5.3	9.5	14	1250	1550	175
TKD20UU	20	25	30	60	54	42	4	8	5	9	55°	19	9	45	32	M 8	18	6.6	11	18	2090	2630	275
TKD25UU	25	30	39	78	67	51	5.5	10	7	11.5	57°	22.5	10	60	40	M10	22	8.4	14	22	3780	4720	558
TKD30UU	30	35	43.5	87	79	60	5.5	12	8	14	57°	26	11.5	68	45	M10	22	8.4	14	26	5470	6810	860
TKD40UU	40	45	54	108	91	77	5	15	10	19.5	56°	26.5	14	86	58	M12	26	10.5	17.5	33	6590	8230	1490

(1) For anti-corrosion the load plates are electroless nickel plated with Stainless Steel ball elements.

1N≐0.102kgf

TKD-W TYPE

— Clearance Adjustable Double-Wide Open Block Type —
(Metric Series)

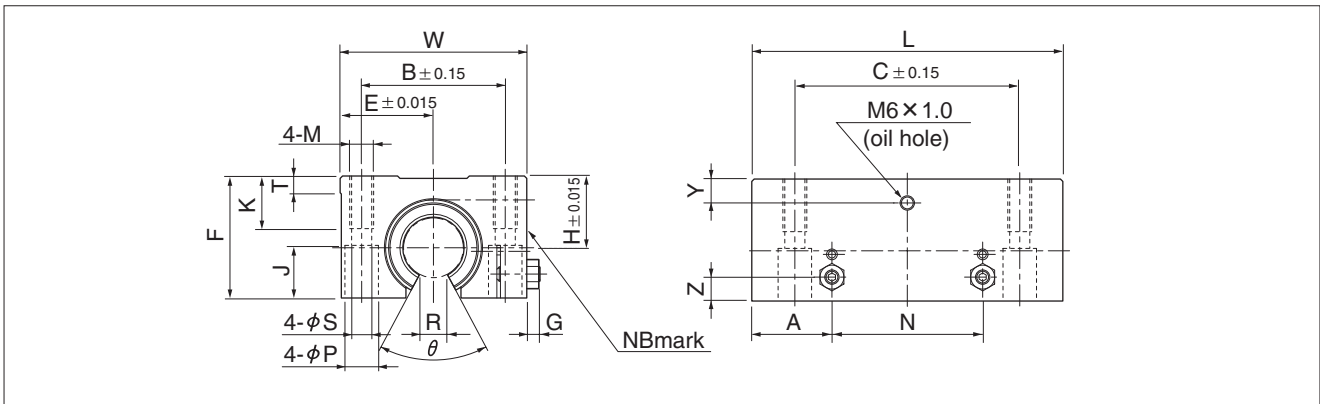
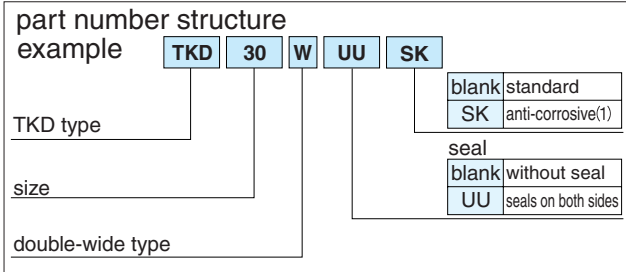

part number	nom. shaft dia. mm	major dimensions													mounting dimensions							load rating		mass g
		H	E	W	L	F	G	Z	A	N	T	R	θ	Y	B	C	M	K	S	P	J	dynamic C N	static Co N	
		mm	mm	mm	mm	mm	mm	mm	mm	mm	mm	mm	mm	mm	mm	mm	mm	mm	mm	mm	mm	mm	mm	
TKD12WUU	12	18	21.5	43	76	28	3.2	5	19.5	37	5	6.5	66°	7.5	32	56	M 5	11	4.3	8	11.5	1652	2580	190
TKD16WUU	16	22	26.5	53	84	35	3.2	6	21.5	41	5	9	68°	9.5	40	64	M 6	13	5.3	9.5	14	2025	3100	312
TKD20WUU	20	25	30	60	104	42	4	8	27	50	5	9	55°	9	45	76	M 8	18	6.6	11	18	3390	5260	505
TKD25WUU	25	30	39	78	130	51	5.5	10	33.5	63	7	11.5	57°	10	60	94	M10	22	8.4	14	22	6120	9440	1050
TKD30WUU	30	35	43.5	87	152	60	5.5	12	39.5	73	8	14	57°	11.5	68	106	M10	22	8.4	14	26	8860	13620	1630
TKD40WUU	40	45	54	108	176	77	5	15	45.5	85	10	19.5	56°	14	86	124	M12	26	10.5	17.5	33	10680	16460	2880

(1) For anti-corrosion the load plates are electroless nickel plated with Stainless Steel ball elements.

1N≐0.102kgf

TWA TYPE

– Block Type –

(Inch Series)

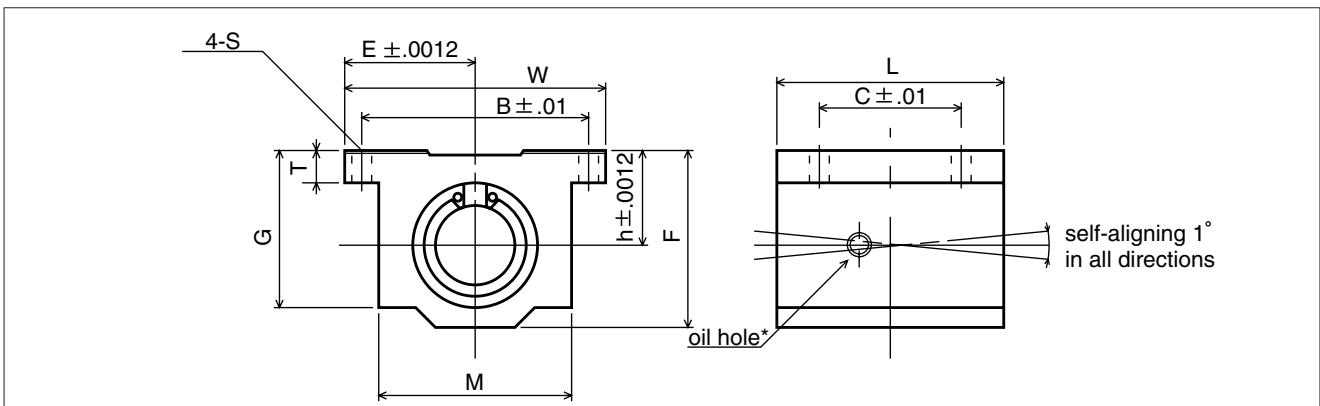
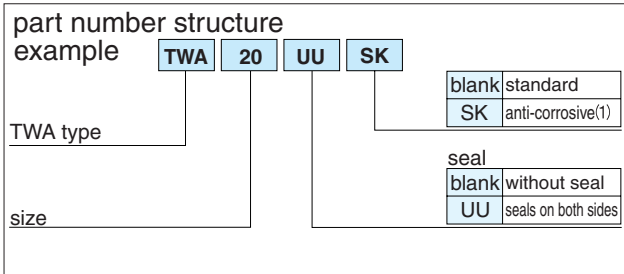

part number	nom. shaft dia. inch	major dimensions								mounting dimensions			basic load rating		mass lbs.
		h inch	E inch	W inch	L inch	F inch	T inch	G inch	M inch	B inch	C inch	S inch	C lbs.	Co lbs.	
TWA 4UU	1/4	.4370	.8125	1.625	1.188	.813	.188	.750	1.000	1.312	.750	.156	60	80	.090
TWA 6UU	3/8	.5000	.8750	1.750	1.313	.938	.188	.875	1.125	1.437	.875	.156	95	120	.120
TWA 8UU	1/2	.6870	1.0000	2.000	1.688	1.250	.250	1.125	1.375	1.688	1.000	.156	230	290	.248
TWA 10UU	5/8	.8750	1.2500	2.500	1.938	1.625	.281	1.437	1.750	2.125	1.125	.188	400	500	.465
TWA 12UU	3/4	.9370	1.3750	2.750	2.063	1.750	.313	1.563	1.875	2.375	1.250	.188	470	590	.553
TWA 16UU	1	1.1870	1.6250	3.250	2.813	2.188	.375	1.938	2.375	2.875	1.750	.219	850	1060	1.200
TWA 20UU	1-1/4	1.5000	2.0000	4.000	3.625	2.813	.438	2.500	3.000	3.500	2.000	.219	1230	1530	2.380
TWA 24UU	1-1/2	1.7500	2.3750	4.750	4.000	3.250	.500	2.875	3.500	4.125	2.500	.281	1480	1850	3.460
TWA 32UU	2	2.1250	3.0000	6.000	5.000	4.063	.625	3.625	4.500	5.250	3.250	.406	2430	3040	6.830

* Provided with push-in oil fitting for 1/4" to 1/2" sizes. Sizes from 5/8" to 2" offer a 1/4-28 tapped hole with a plug for adding a fitting if desired.

(1) For anti-corrosion the load plates are electroless nickel plated with Stainless Steel ball elements.

1inch = 25.4mm

1lbs ≈ 0.454kg

1lbs ≈ 4.448N

TWA-W TYPE

— Double-Wide Block Type —

(Inch Series)

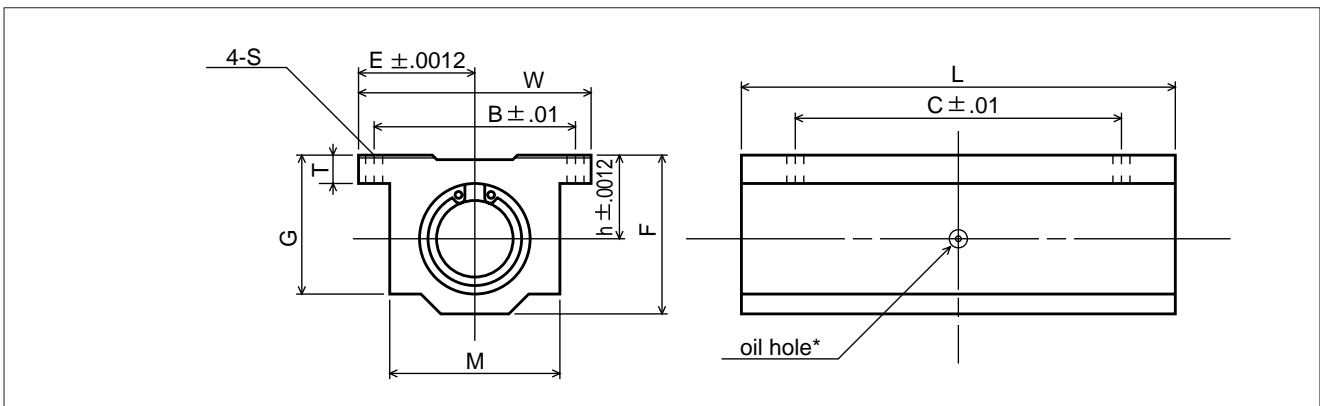
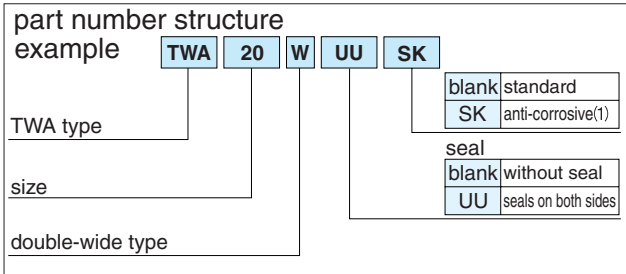
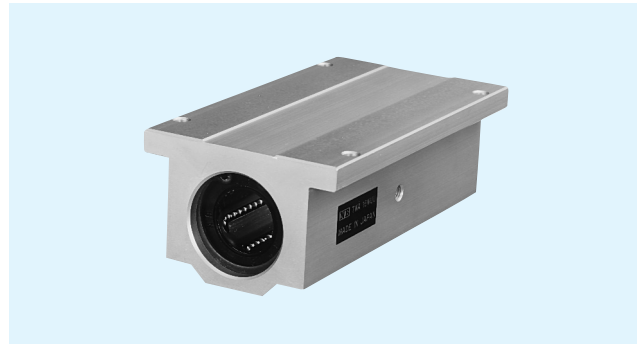

part number	nom. shaft dia. inch	major dimensions								mounting dimensions			basic load rating		mass lbs.
		h inch	E inch	W inch	L inch	F inch	T inch	G inch	M inch	B inch	C inch	S inch	C lbs.	Co lbs.	
TWA 4WUU	1/4	.4370	.8125	1.625	2.500	.813	.188	.750	1.000	1.312	2.000	.156	96	160	.190
TWA 6WUU	3/8	.5000	.8750	1.750	2.750	.938	.188	.875	1.125	1.437	2.250	.156	150	240	.250
TWA 8WUU	1/2	.6870	1.0000	2.000	3.500	1.250	.250	1.125	1.375	1.688	2.500	.156	370	580	.510
TWA 10WUU	5/8	.8750	1.2500	2.500	4.000	1.625	.281	1.437	1.750	2.125	3.000	.188	640	1000	1.000
TWA 12WUU	3/4	.9370	1.3750	2.750	4.500	1.750	.313	1.563	1.875	2.375	3.500	.188	750	1180	1.200
TWA 16WUU	1	1.1870	1.6250	3.250	6.000	2.188	.375	1.938	2.375	2.875	4.500	.219	1360	2120	2.400
TWA 20WUU	1-1/4	1.5000	2.0000	4.000	7.500	2.813	.438	2.500	3.000	3.500	5.500	.219	1970	3060	5.000
TWA 24WUU	1-1/2	1.7500	2.3750	4.750	9.000	3.250	.500	2.875	3.500	4.125	6.500	.281	2370	3700	7.800

* Provided with push-in oil fitting for 1/4" to 1/2" sizes. Sizes from 5/8" to 2" offer a 1/4-28 tapped hole with a plug for adding a fitting if desired.

(1) For anti-corrosion the load plates are electroless nickel plated with Stainless Steel ball elements.

1inch = 25.4mm
1lbs ≈ 0.454kg
1lbs ≈ 4.448N

TWJ TYPE

— Clearance Adjustable Block Type —
(Inch Series)

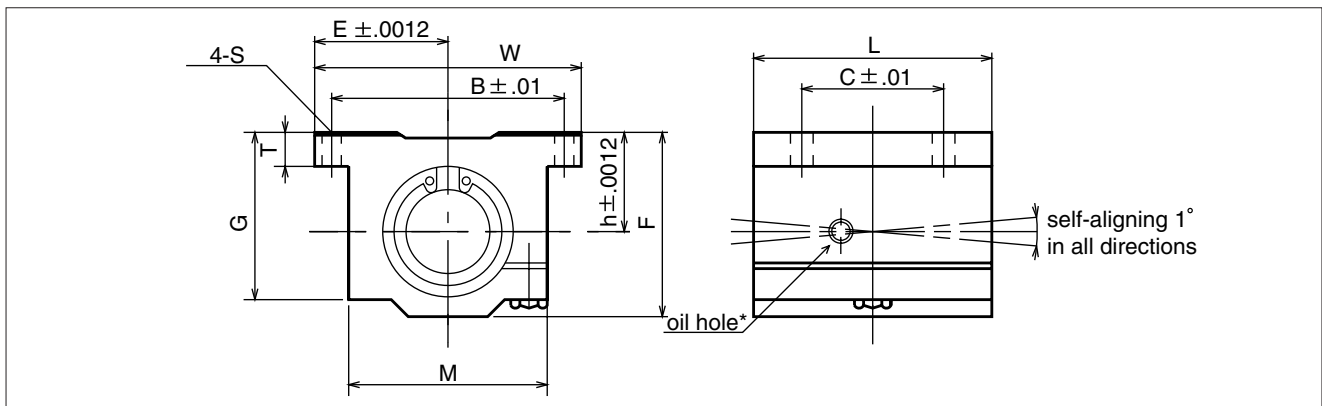
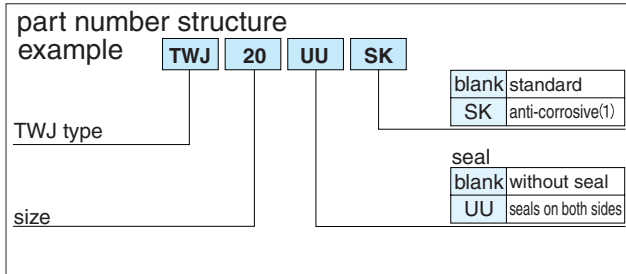
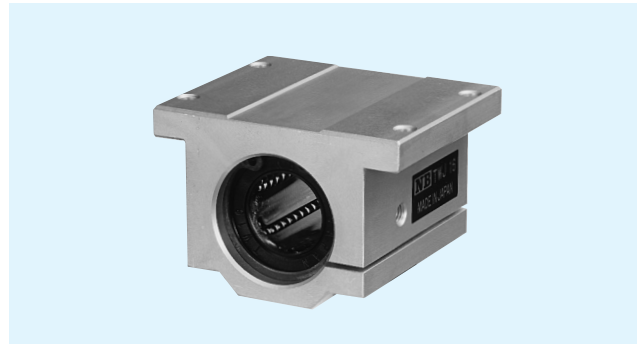

part number	nom. shaft dia. inch	major dimensions								mounting dimensions			basic load rating		mass lbs.
		h inch	E inch	W inch	L inch	F inch	T inch	G inch	M inch	B inch	C inch	S inch	C lbs.	Co lbs.	
TWJ 4UU	1/4	.4370	.8125	1.625	1.188	.813	.188	.750	1.000	1.312	.750	.156	60	80	.090
TWJ 6UU	3/8	.5000	.8750	1.750	1.313	.938	.188	.875	1.125	1.437	.875	.156	95	120	.120
TWJ 8UU	1/2	.6870	1.0000	2.000	1.688	1.250	.250	1.125	1.375	1.688	1.000	.156	230	290	.248
TWJ 10UU	5/8	.8750	1.2500	2.500	1.938	1.625	.281	1.437	1.750	2.125	1.125	.188	400	500	.465
TWJ 12UU	3/4	.9370	1.3750	2.750	2.063	1.750	.313	1.563	1.875	2.375	1.250	.188	470	590	.553
TWJ 16UU	1	1.1870	1.6250	3.250	2.813	2.188	.375	1.938	2.375	2.875	1.750	.219	850	1060	1.200
TWJ 20UU	1-1/4	1.5000	2.0000	4.000	3.625	2.813	.438	2.500	3.000	3.500	2.000	.219	1230	1530	2.380
TWJ 24UU	1-1/2	1.7500	2.3750	4.750	4.000	3.250	.500	2.875	3.500	4.125	2.500	.281	1480	1850	3.460
TWJ 32UU	2	2.1250	3.0000	6.000	5.000	4.063	.625	3.625	4.500	5.250	3.250	.406	2430	3040	6.830

* Provided with push-in oil fitting for 1/4" to 1/2" size. Sizes from 5/8" to 2" offer a 1/4-28 tapped hole with a plug for adding a fitting if desired.

(1) For anti-corrosion the load plates are electroless nickel plated with Stainless Steel ball elements.

1inch = 25.4mm

1lbs ≈ 0.454kg

1lbs ≈ 4.448N

TWJ-W TYPE

— Clearance Adjustable Double-Wide Block Type —

(Inch Series)

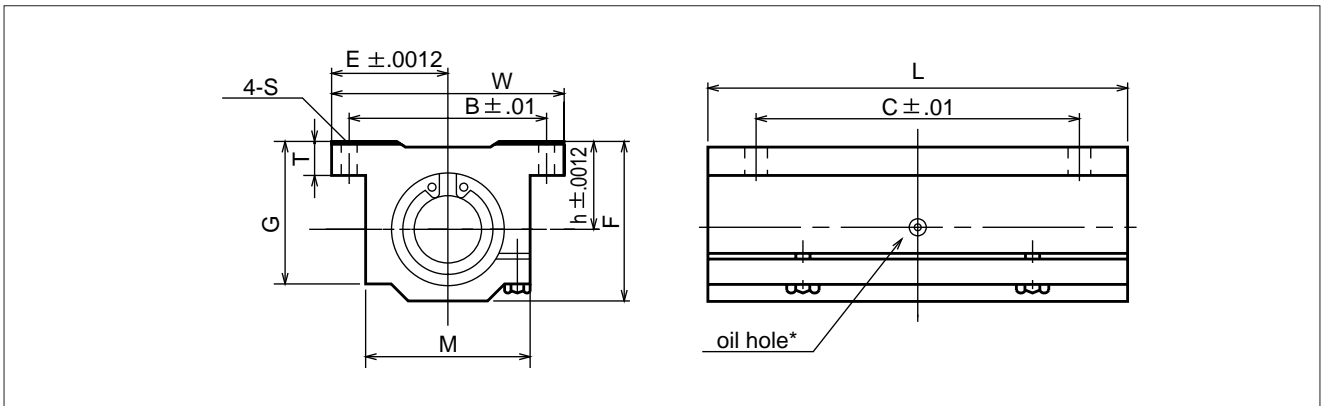
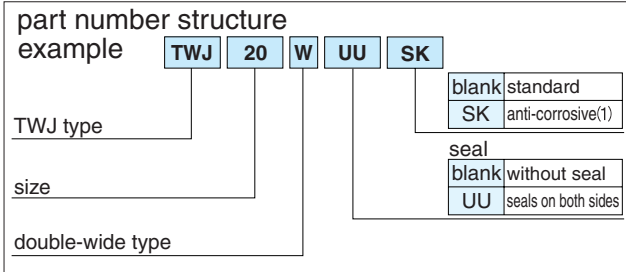
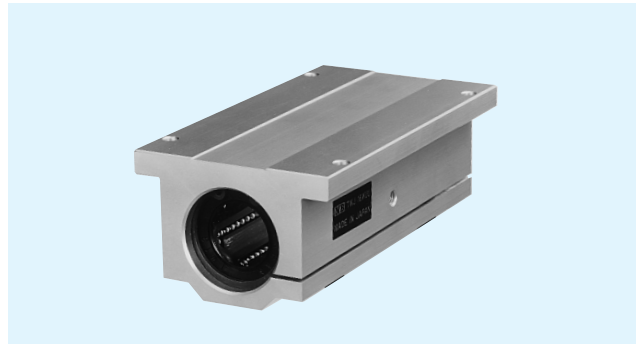

part number	nom. shaft dia. inch	major dimensions								mounting dimensions			basic load rating		mass lbs.
		h inch	E inch	W inch	L inch	F inch	T inch	G inch	M inch	B inch	C inch	S inch	C lbs.	Co lbs.	
TWJ 4WUU	1/4	.4370	.8125	1.625	2.500	.813	.188	.750	1.000	1.312	2.000	.156	96	160	.190
TWJ 6WUU	3/8	.5000	.8750	1.750	2.750	.938	.188	.875	1.125	1.437	2.250	.156	150	240	.250
TWJ 8WUU	1/2	.6870	1.0000	2.000	3.500	1.250	.250	1.125	1.375	1.688	2.500	.156	370	580	.510
TWJ 10WUU	5/8	.8750	1.2500	2.500	4.000	1.625	.281	1.437	1.750	2.125	3.000	.188	640	1000	1.000
TWJ 12WUU	3/4	.9370	1.3750	2.750	4.500	1.750	.313	1.563	1.875	2.375	3.500	.188	750	1180	1.200
TWJ 16WUU	1	1.1870	1.6250	3.250	6.000	2.188	.375	1.938	2.375	2.875	4.500	.219	1360	2120	2.400
TWJ 20WUU	1-1/4	1.5000	2.0000	4.000	7.500	2.813	.438	2.500	3.000	3.500	5.500	.219	1970	3060	5.000
TWJ 24WUU	1-1/2	1.7500	2.3750	4.750	9.000	3.250	.500	2.875	3.500	4.125	6.500	.281	2370	3700	7.800

* Provided with push-in oil fitting for 1/4" to 1/2" size. Sizes from 5/8" to 2" offer a 1/4-28 tapped hole with a plug for adding a fitting if desired.

(1) For anti-corrosion the load plates are electroless nickel plated with Stainless Steel ball elements.

1inch = 25.4mm
1lbs ≈ 0.454kg
1lbs ≈ 4.448N

TWD TYPE

— Open Block Type —

(Inch Series)

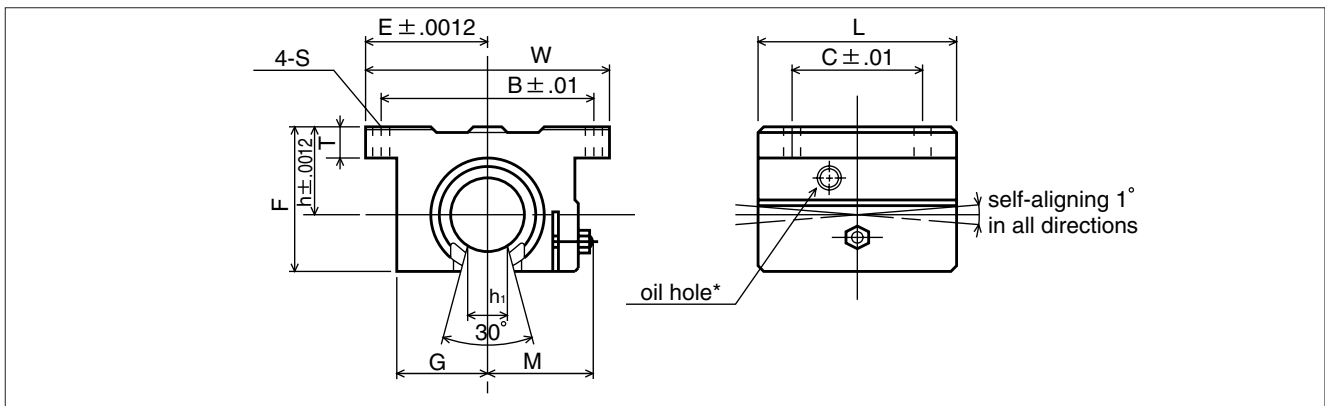
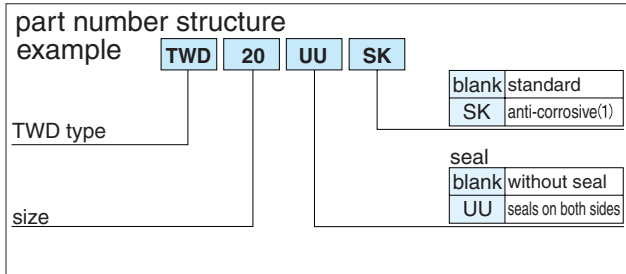

part number	nom. shaft dia. inch	major dimensions									mounting dimensions			basic load rating		mass lbs.
		h inch	E inch	W inch	L inch	F inch	T inch	G inch	M inch	h ₁ inch	B inch	C inch	S inch	C dynamic lbs.	Co static lbs.	
TWD 8UU	1/2	.6870	1.000	2.000	1.500	1.100	.250	.688	.98	.260	1.688	1.000	.156	230	290	.188
TWD 10UU	5/8	.8750	1.2500	2.500	1.750	1.405	.281	.875	1.15	.319	2.125	1.125	.188	400	500	.365
TWD 12UU	3/4	.9370	1.3750	2.750	1.875	1.535	.315	.937	1.23	.386	2.375	1.250	.188	470	590	.452
TWD 16UU	1	1.1870	1.6250	3.250	2.625	1.975	.375	1.188	1.48	.512	2.875	1.750	.218	850	1060	1.010
TWD 20UU	1-1/4	1.5000	2.0000	4.000	3.375	2.485	.437	1.500	1.88	.569	3.500	2.000	.218	1230	1530	1.980
TWD 24UU	1-1/2	1.7500	2.3750	4.750	3.750	2.910	.500	1.750	2.12	.681	4.125	2.500	.281	1480	1850	2.950
TWD 32UU	2	2.1250	3.0000	6.000	4.750	3.660	.625	2.250	2.70	.933	5.250	3.250	.406	2430	3040	5.840

* Provided with push-in oil fitting for 1/4" to 1/2" size only. Sizes from 5/8" to 2" offer a 1/4-28 tapped hole with a plug for adding a fitting if desired.

(1) For anti-corrosion the load plates are electroless nickel plated with Stainless Steel ball elements.

1inch = 25.4mm
1lbs ≈ 0.454kg
1lbs ≈ 4.448N

TWD-W TYPE

— Double-Wide Open Block Type —
 (Inch Series)

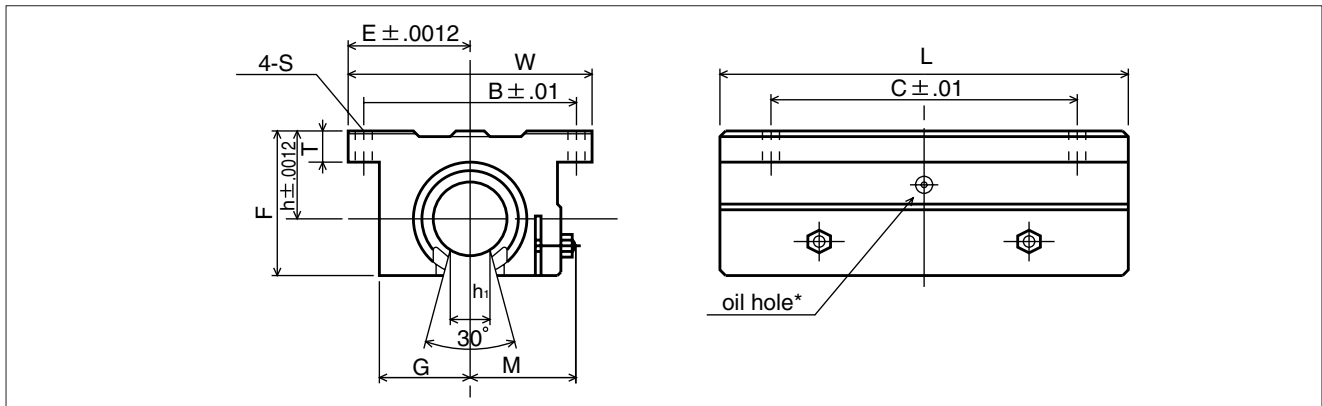
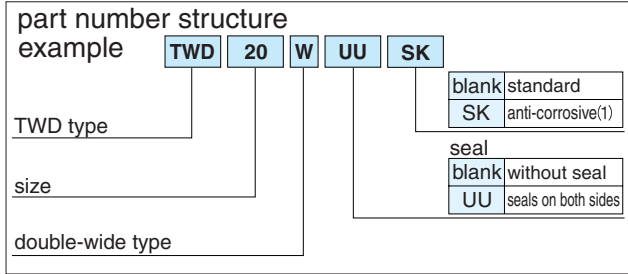
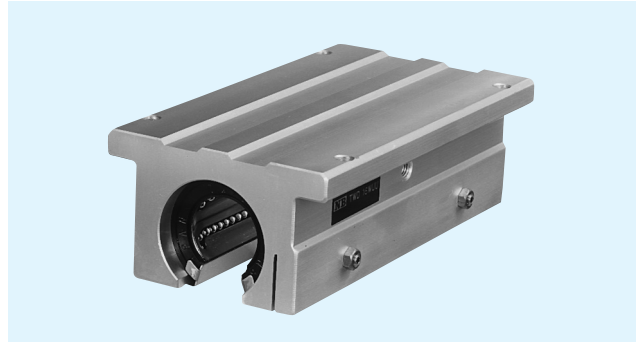

part number	nom. shaft dia. inch	major dimensions									mounting dimensions			basic load rating		mass lbs.
		h inch	E inch	W inch	L inch	F inch	T inch	G inch	M inch	h ₁ inch	B inch	C inch	S inch	C lbs.	Co lbs.	
TWD 8WUU	1/2	.6870	1.000	2.000	3.500	1.100	.250	.688	.98	.260	1.688	2.500	.156	370	580	.400
TWD 10WUU	5/8	.8750	1.2500	2.500	4.000	1.405	.281	.875	1.15	.319	2.125	3.000	.188	640	1000	.800
TWD 12WUU	3/4	.9370	1.3750	2.750	4.500	1.535	.315	.937	1.23	.386	2.375	3.500	.188	750	1180	1.000
TWD 16WUU	1	1.1870	1.6250	3.250	6.000	1.975	.375	1.188	1.48	.512	2.875	4.500	.218	1360	2120	2.000
TWD 20WUU	1-1/4	1.5000	2.0000	4.000	7.500	2.485	.437	1.500	1.88	.569	3.500	5.500	.218	1970	3060	4.200
TWD 24WUU	1-1/2	1.7500	2.3750	4.750	9.000	2.910	.500	1.750	2.12	.681	4.125	6.500	.281	2370	3700	6.700

* Provided with push-in oil fitting for 1/4" to 1/2" size. Sizes from 5/8" to 2" offer a 1/4-28 tapped hole with a plug for adding a fitting if desired.

(1) For anti-corrosion the load plates are electroless nickel plated with Stainless Steel ball elements.

1inch = 25.4mm
 1lbs ≅ 0.454kg
 1lbs ≅ 4.448N